



1.0 Introduction

This document provides an introduction to design and installation aspects of the Kee Access system. It is part of the support documentation issued to Kee Safety Ltd personnel, distributors and partners / installers, or any other interested parties.

Information contained in this document may be of a sensitive nature and may not be conveyed to any third party without the prior permission of Kee Safety Ltd.

Every care has been taken to ensure the information given in this manual is correct at the time of publication. Kee Safety Limited reserve the right to alter any information without notice as circumstances dictate, in line with their policy of continual development and improvement.

Units.

All dimensions are in millimetres unless otherwise stated, and angles are specified in degrees.

2.0 System Overview

The Kee Access Hand rail system has been developed by Kee Safety Limited to meet the requirements of Building Regulations Approved Document Part M: 2004, and BS 8300: 2001. The system can be used in 'new-build' or 'upgrades' allowing existing systems of size 7 or 8 to meet the new standards.

Our stringent quality control process has been applied throughout the design and manufacture of the Kee Access System.

3.0 Design Risk Assessment

As required by Health & Safety legislation, all new Kee Safety Limited products undergo Design Risk Assessment. - See Kee Safety Limited D.R.A. sheet 'Instructions for the design and installation of handrail systems using Kee Access System.

A précised version is incorporated in section 7.0 (Do's & Don'ts).

4.0 Rules & Regulations

4.1 Introduction

It is worth remembering that the people 'policing' the DDA are people with disabilities, so one must take reasonable measures not to discriminate against any disability group, and hence the Kee Access System has been designed within the guidelines set out in Building Regulations Approved Document Part M: 2004 and BS8300: 2001.

4.2 Measuring Heights of Hand Rails and Guarding

The requirements regarding stairways and ramps are set out in approved document Part K & Part M: 2004 of the Building Regulations, with Part M taking precedence in conflicting areas.

'Guard' and 'hand' rails are measured vertically from floor ('nosing' for steps) to top of 'top rail' and are required where there is a change of levels of a) 600mm (private dwellings) or b) two or more 'risers' - or 380mm – (in all other buildings) Approved Document Part K (1-5).

Minimum guardrail heights are 900mm for stairs and ramps, and 1100mm in all other locations.

N.B. this does not include single-family dwellings.

Handrails are to be 900mm to 1100mm high on level sections, and 900mm to 1000mm on raking / stepped sections, as specified in Building Regulations Approved Document Part M: 2004 (section 1.37a), and BS 8300: 2001 (section 5.9.7.2)

4.3 Tube diameters

Approved Document M: 2004 and BS 8300: 2001 contain details on access facilities for disabled people. The sizes designated for handrails are 40-45mm O.D. in Part M: 2004 (1.37 diagram 7), and 40-50mm O.D. in BS 8300 (5.10.2 Figure 11).

The handrail used with the Kee Access system is size 7 (42.4mm O.D.).

4.4 Finishes

Page 26. 1.37 b) of Approved Document Part M: 2004, states: 'finished so as to contrast in colour and luminance with the surroundings against which it is seen without being highly reflective'.

Page 26. 1.37 f) of Approved Document Part M: 2004, states: 'its surface is slip resistant and not cold to the touch'.

Page 22. 5.10.1 c) of BS 8300: 2001, states: 'easy and comfortable to grip with no sharp edges, smooth and not cold to the touch.

Page 22. 5.10.1 Note 2 states 'the use of wood or certain coatings, such as powdered nylon, is recommended as a finish'. ***

Therefore the system has been designed to be smooth and continuous and, either the system, or just the handrail can be painted, polyester powder coated or have any equivalent coating applied to make it contrast visually with the background against which it is seen, and not cold to the touch.

***** Kee Safety Limited has obtained written confirmation from BSI Global that polyester powder coating is an acceptable finish.**

5.0 Components

The following components make up the Kee Access system and are all purpose components – except the 18-7 from the standard Kee Klamp component range. The dimensions have been calculated assuming the use 7-2-G handrail tube, but some of the components could be used with Size 8 Tube.

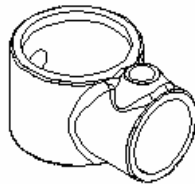

10-848

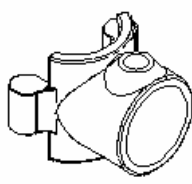

A10-748

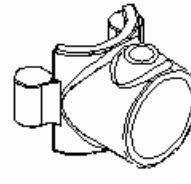

A10-848

All of the above 'tee' components are used as an interface between uprights and the Kee Access components.

The 10-848 is for new build, whilst the A10-748 and A10-848 are for upgrading size 7 and size 8 systems respectively.

N.B. the add-on components are shown without their retaining caps or pins (U7000, & U8000).

5.0 Components (cont'd)

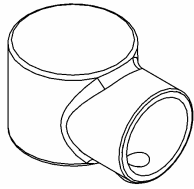

10-840C

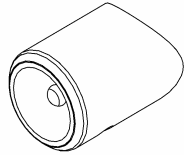

410 - 8

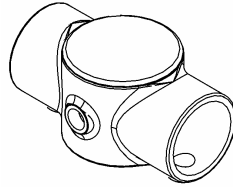

26-840C

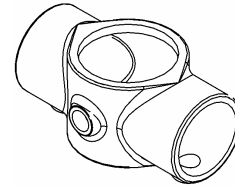

26-840

These four also join to the uprights. The 10-840C provides single side bracket support for the handrail and eliminates the need for an 84 fitting to cap the upright, whilst the 26-840C does the same whilst providing double bracket support for 'central flight' style handrails. The 26-840 provides double side bracket support for mid height handrails. The 410-8 is secured to the upright using an M6 Beam Clamp 'box-bolt' and holds the 418-40 in place by means of 2 grub-screws.

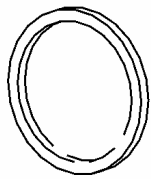

508-7

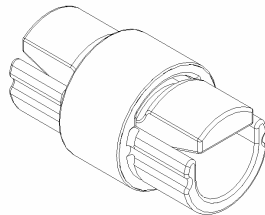

514-7

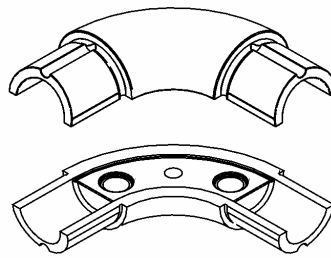

515-7T & 515-7B

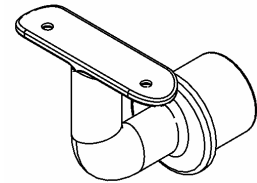

518-7

The 508-7 is a rubber gasket (only in black) and can be used as an optional extra (especially where there is a cut end).

The 514-7 is a straight internal tube joiner, the ends are positioned within the tube ends, and the grub screw tightened, pushing the two halves apart, joining the rail sections.

The 515-7 is a 90° corner elbow, that works in much the same way as the 18-7 fitting, except the 515-7 B & T are joined by a centrally positioned screw. The combined component is positioned with the ends inside the adjoining handrails, and the outer grub-screws tightened. This forces the halves apart, gripping the inside of the tube. The central is then tightened, locking the fitting in place.

The 518-7 component is an intermediate upright handrail support. Mounted on an upright using a 10-840 or an A10, the rail sits on the saddle and is secured by either Ø4.8mm x 15mm long aluminium 'multi-grip' pop rivets or No. 10 x 20mm countersunk self-tapping screws.

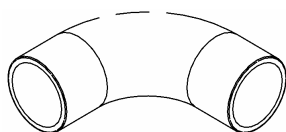

520-7

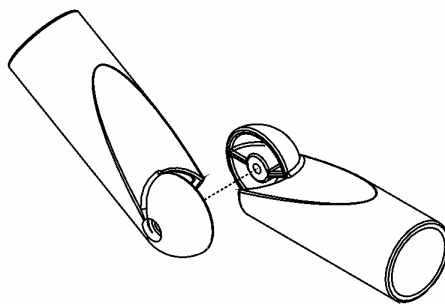

554-7 (L.H. & R.H.)



565-7

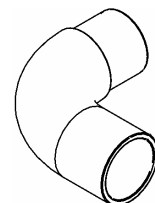

567-7

5.0 Components (cont'd)

The 520-7 is an alternative elbow to the 515, and is joined to the handrails by 514-7's or 18-7's. The 554-7 is a variable angle elbow for changes in elevation or in plan, and are joined to the rails with 514-7's or 18-7's. The 565-7 is a wall mounted handrail return bracket, and should be joined to the handrail using a 514-7 or 18-7 fitting. The 567-7 is the upright mounted version of the 565-7.

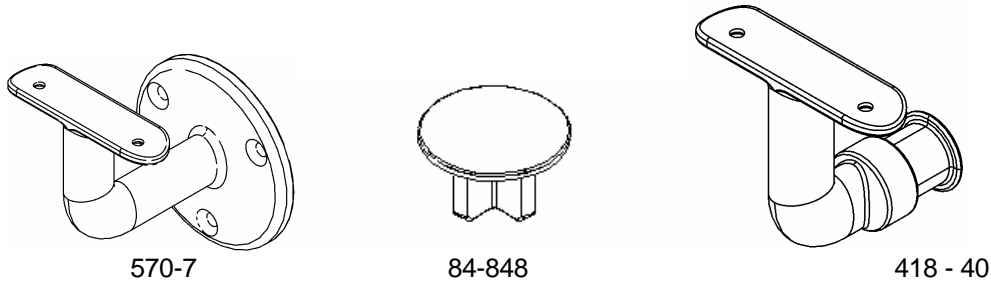

The 570-7 is the wall-mounted version of the 518-7, and again the handrail tube sits on the 'saddle', and is secured using either No. 10 self-tapping screws, or multi-grip pop rivets.

The 84-848 is a cap for the open ends of size 8 uprights, and covers the top of a 10-848 'tee' fitting. 77-7's, 77-8's, 84-7's or 84-8's could also be used, but do not cover the 10-848 fitting.

The 418-40 connects the 410-8 to the handrail. The barrel connection into the 410-8 has a groove for grub-screw location this also facilitates lateral adjustment of +/-5mm. The 418-40 fitting can be rotated before tightening the grub-screws, to accommodate ramps and stairs.

The handrail is secured to the 418-40 by means of either 2 self-tapping screws (No. 10 x 20mm) or 'multi-grip' pop-rivets (Ø4.8 x 15mm).

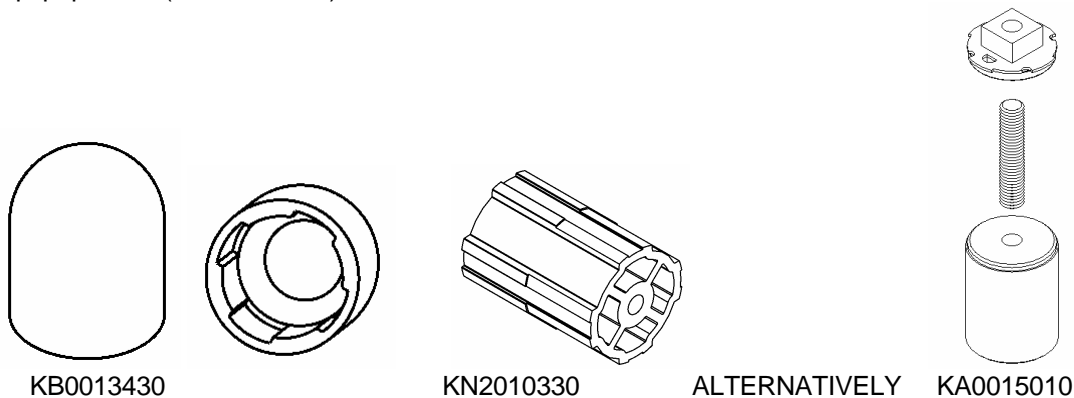

The KB0013430 Ball End is used to finish off open-ended uprights, and is secured using a KN2010330 steel upright to handrail connector (which may need cutting down to size), which is jointed to the parts by pop-rivets – bear in mind that these should be positioned carefully / strategically for aesthetics and functionality. Alternatively fixing of the Ball End to Upright can be made using the KeeNect Upright insert when using KeeNect Upright tube.

5.0 Components (cont'd)

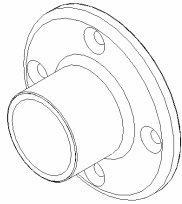

561 – 7

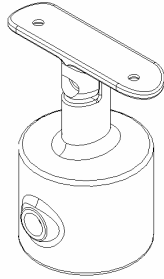

555 – 8

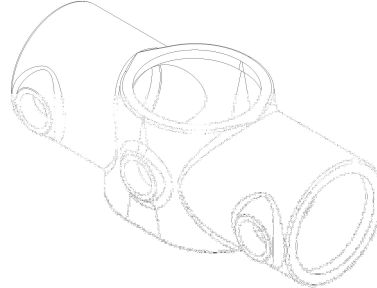

89 - 87

The 561-7 is a wall mounted handrail end bracket, and should be joined to the handrail using a 514-7 or 18-7. The 555-8 is an in-line adjustable angle single top rail post mounted component for when a guidance handrail is required and where there is not the need for a twin rail guardrail style system. The 89 – 87 would typically be used to form a Non-DDA compliant Size 7 mid rail and would be used in conjunction with the 555-8 in-line top rail component.

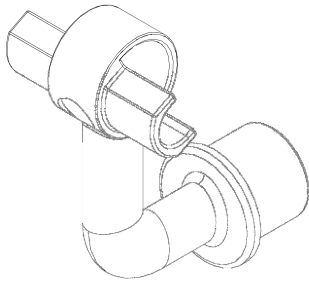

575 – 7

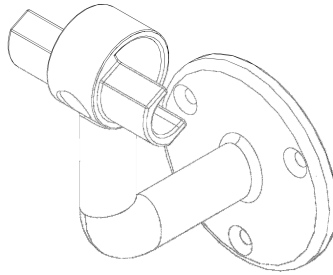

580 – 7

The 575-7 is a Upright mounted handrail Intermediate support bracket with the added function of being able to join the Handrail Tube at the same location. The 580-7 is a wall mounted handrail Intermediate support bracket with the added function of being able to join the Handrail Tube at the same location. .

6.0 Specifying the Kee Access Range

One important thing to consider when specifying a system is the environment it is to be used in. To achieve the 'not cold to the touch' part of current legislation, the Kee Access system must be polyester powder coated, and while this coating, and the grub-screws or pop rivets have sufficient durability for normal day-to-day use, they may not fair so well against the actions of determined vandals.

Upright mounted:

Multiple bays of continuous level, raking and changing direction in plan hand & mid-rail (as required), off-set from uprights using [reducing] 'tee' fittings of standard or add-on variety. Handrails of Galvanised mild steel (to BS EN 10255 or equivalent) and supports of either Galvanised ductile cast iron (to BS EN 1563) or Aluminium Alloy.

Polyester powder coated for contrasting colour / appearance to its surroundings. Open-ended uprights should be capped.

The support provided by the brackets is from the underside of the handrail to give a continuous rail

facility, as required in BS8300: 2001 & the approved document Part M: 2004 of the Building Regulations.

Handrails to extend 300mm past the end of the steps or ramp as required in BS8300: 2001 and the approved document Part M: 2004 of the Building Regulations.

Wall mounted:

Multiple bays, level, raking and changing direction in plan wall mounted hand railing, secured to the wall with brackets at 1800mm maximum centres, complete with stainless steel fixing screws. Handrails of galvanised mild steel (to BS 1387 or equivalent) and supports of galvanised ductile cast iron (to BS EN 1563) respectively. Polyester powder coated for contrasting colour / appearance to its surroundings. Both ends to be returned to wall with wall return brackets. The support provided by the brackets is from the underside of the handrail to give a continuous rail facility, as required in BS8300: 2001 & the approved document Part M: 2004 of the Building Regulations. Handrails to extend 300mm past the end of the steps or ramp as required in BS8300: 2001 and the approved document Part M: 2004 of the Building Regulations.

7.0 Do's & Don'ts

The following are general rules of design and installation, to guarantee a correct, safe and Kee Safety Limited compliant system.

- a) Always carry out load calculation checks before fitting to existing frameworks.
- b) All grub screws must be tightened sufficiently. (39Nm for standard components)
- c) All supporting brackets must be a minimum of 100mm (to centre line) from a tube end, to allow sufficient room for the rivets or screws (see diagram below).

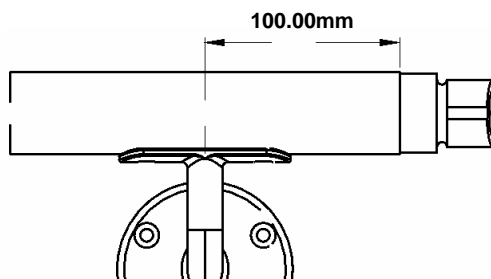

- d) Ensure correct alignment of brackets to tubes before fixing, as incorrect fixing creates additional stress.
- e) Adequately support every elbow with brackets (within 250mm, on at least one side) – making sure that there are no other joins before the first support (bracket or upright), with the 554-7 requiring support on both sides.
- f) Check the wall composition before fixing brackets, as additional support may be required.
- g) Use fixings appropriate to the task.
- h) Always try to carry out a full survey, as this leads to easier installation. If rails do require cutting on site, always de-bur, and treat cut ends accordingly to help prevent the onset of rust i.e. zinc rich cold galvanising paint.
- i) The 508-7 gasket is an optional extra, KS Ltd. do recommend their use with cut ends - after the application of zinc rich cold galvanising paint.
- j) Do consider where possible, extending rail runs past the minimum requirement (i.e. 300mm overshoot), especially when dealing with 'closed loop' systems.

- k) On the ends of spline walls (see below) always ensure that a 570-7 is located to prevent the 515-7 or 520-7 corner elbows from coming loose.

N.B. when using 515-7 elbows, the minimum wall width for this arrangement using standard fittings is: 94mm

When using 520-7 elbows the minimum wall width is negligible as you could butt the elbows together and support with the central 570-7 fitting.

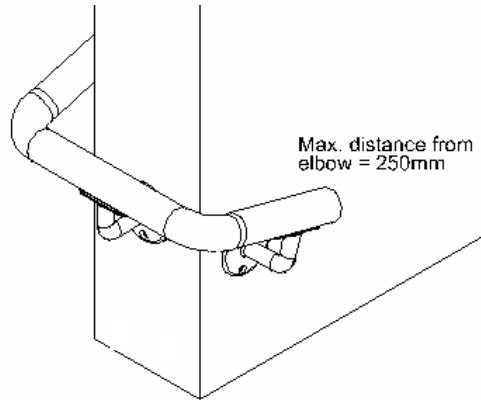

Spline Wall with 570-7 for support (see 6.k.).

Do's & Don'ts Contd.

- l) Standardise components i.e. use 515-7's or 520's throughout, try not to mix between the two.
- m) When using 520-7's as a scroll end on a 'dual' handrail it will be necessary to use a 130mm length of size 6 tube as an internal joiner between the 520's, with the components riveted together.
- n) When using 520's as a scroll bend the 514's used to join the 520's to the handrails must be secured with a rivet on both sides of the joint.
- o) Similarly when using 515's the fitting must be secured to the handrail with a rivet to prevent accidental pull out of the scroll form the handrail.

8.0 Illustrations

514-7 (1 unit =2 halves) 0.34kg

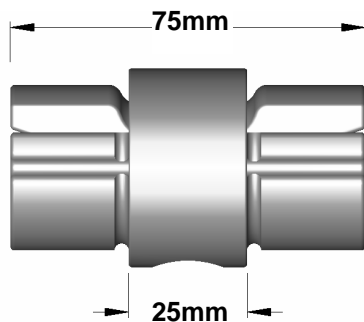

515-7 (B=0.42kg, T=0.47kg)

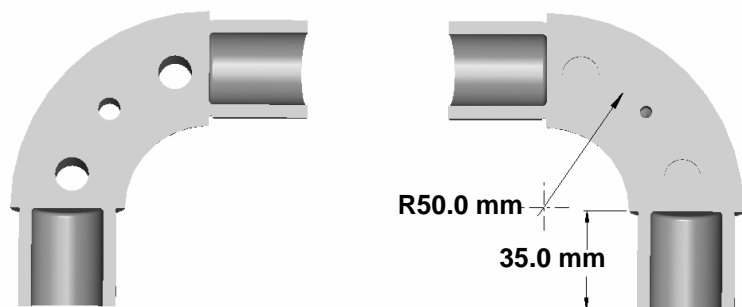

8.0 Illustrations (Contd)

518-7 (0.49kg)

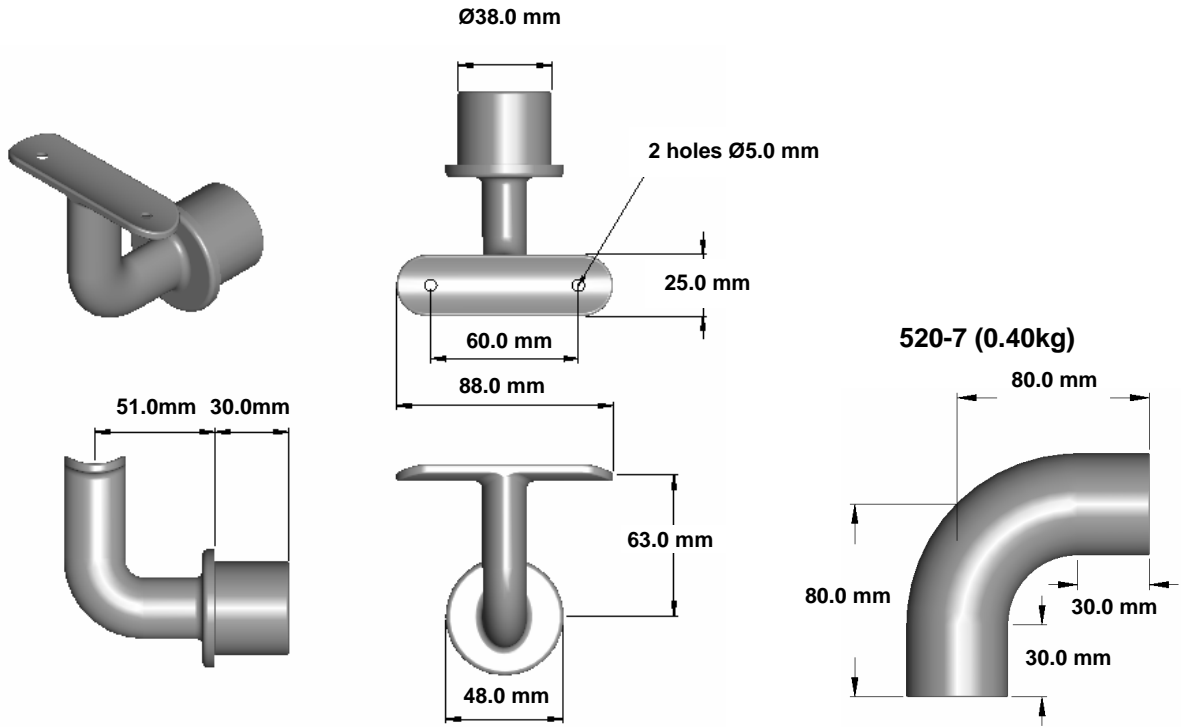

554-7 (0.33kg - each)

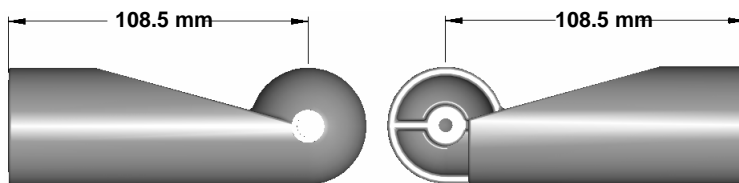

565-7 (0.67kg)

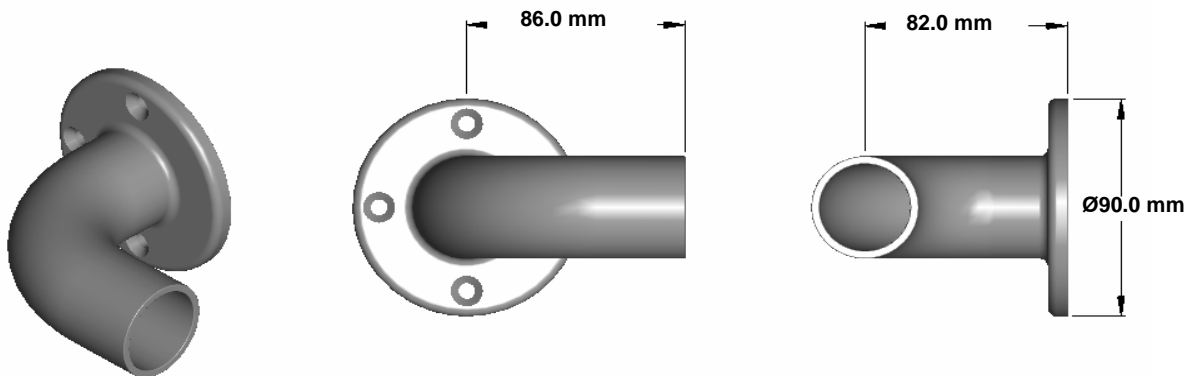

Fixing holes drilled & csk to suit No. 12 csk woodscrews

8.0 Illustrations (Contd)

567-7 (0.49kg)

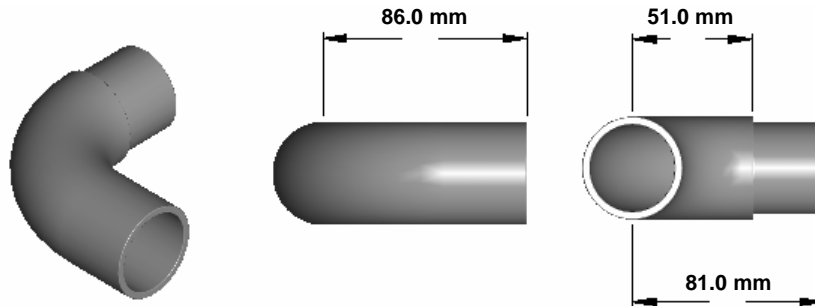

570-7 (0.67kg)

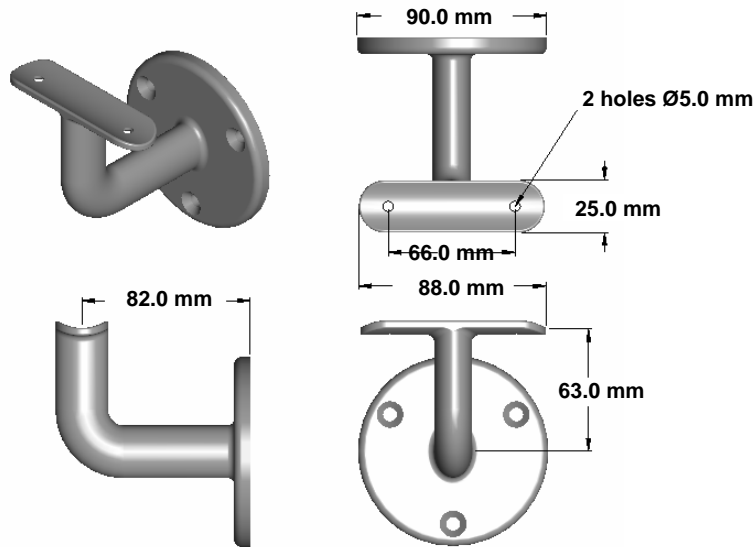

Fixing holes drilled & csk to suit No. 12 csk woodscrews

A10-848 (0.30kg) & A10-748 (0.28kg)

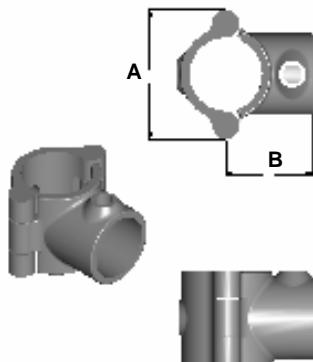

A10-848. A = 82mm, B = 55mm
 A10-748. A = 76mm, B = 53mm

10-848 (0.38kg)

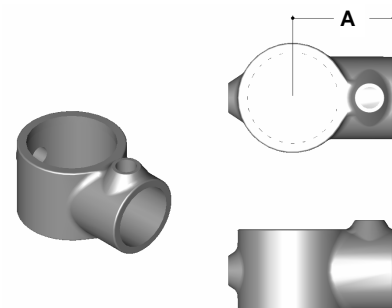

10-848. A = 55mm

8.0 Illustrations (cont'd)

10-840C (0.41kg)

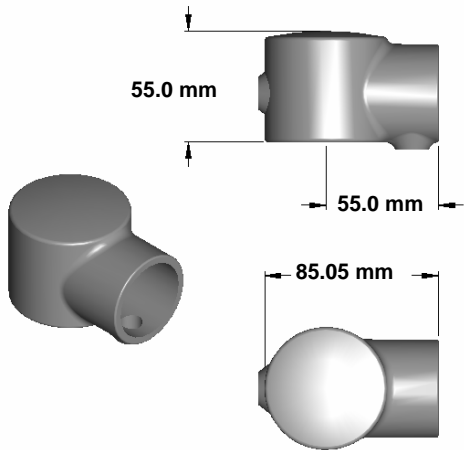

26-840 (0.44kg)

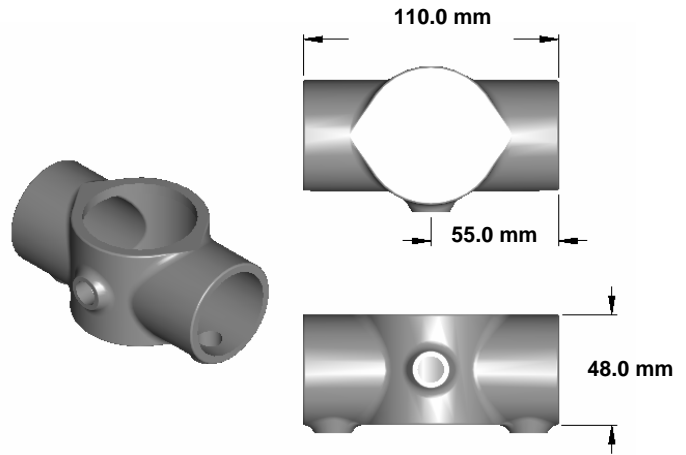

26-840C (0.50kg)

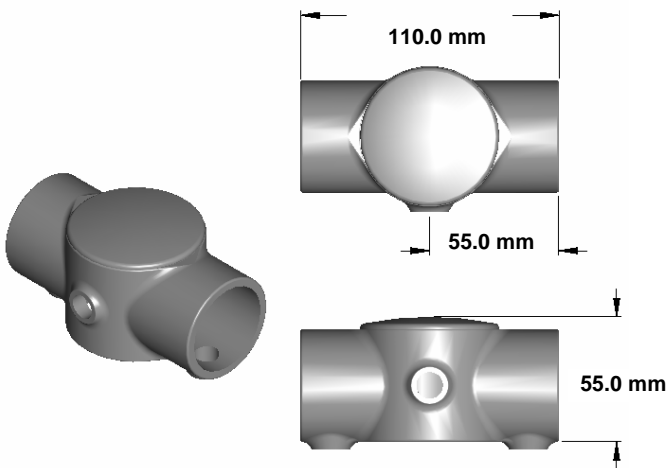

561- 7 (0.35kg)

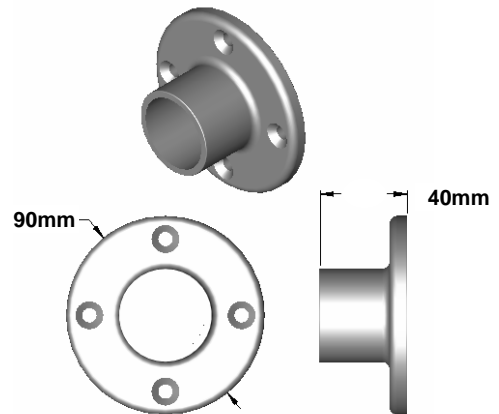

8.0 Illustrations (cont'd)

410 – 8 (0.08 kg)

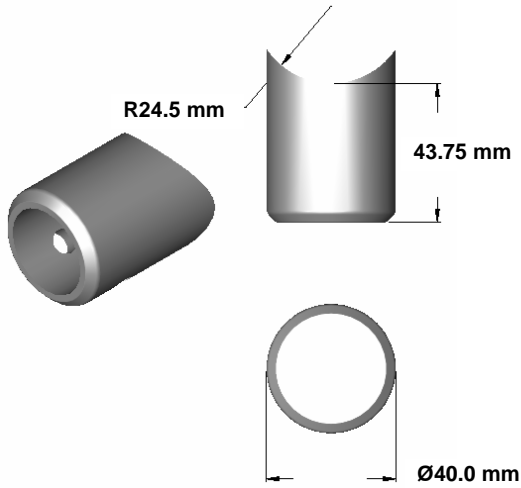

418 – 40 (0.14 kg)

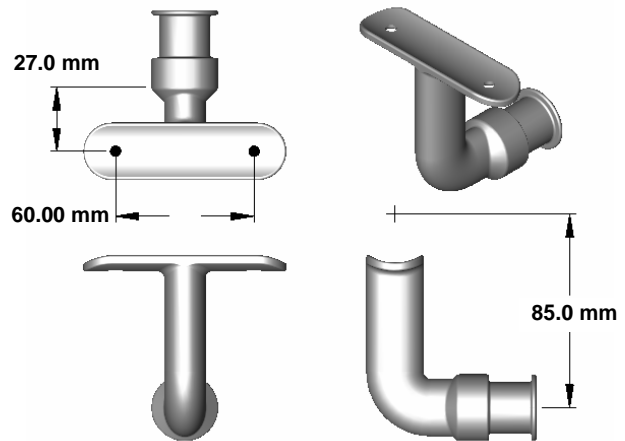

555 – 8 (0.50 kg)

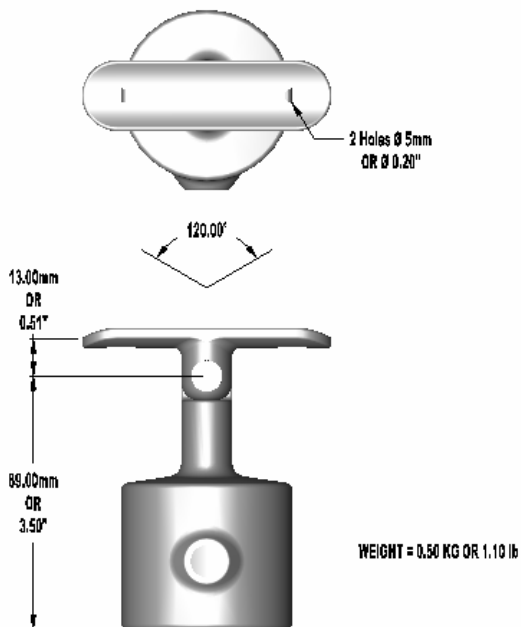

89 – 87 (0.78 kg)

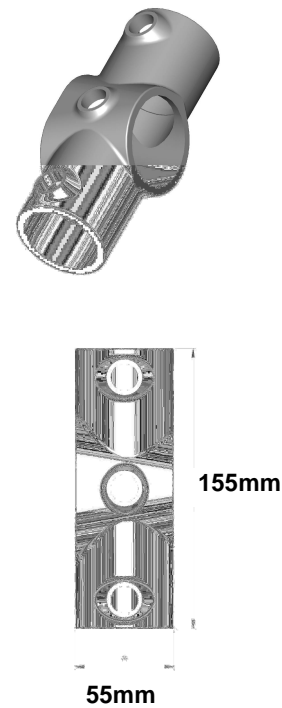

8.0 Illustrations (cont'd)

575 – 7 (0.83 kg)

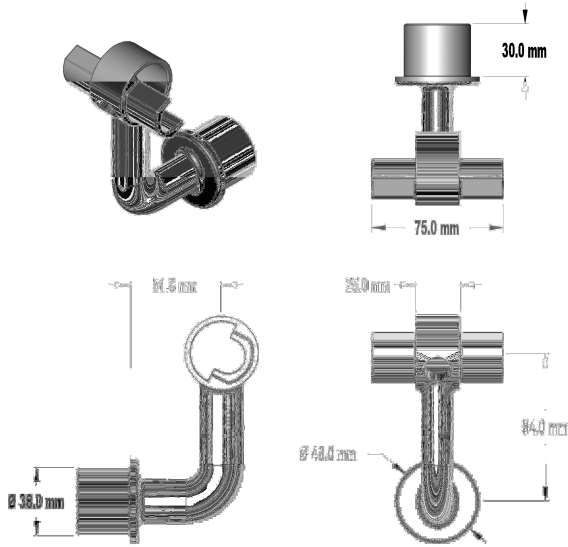

580 – 7 (1.00 kg)

