

## For Your Safety

### 1. BASIC SAFETY INSTRUCTIONS

Basic safety instructions for the safe handling of the KeeWalk® Step Over system can be found here.

#### DANGER TO LIFE!

It is imperative that you follow these safety instructions to avoid endangering your life and safety.



Possible Danger	Prevention Measures
<p><b>DANGER TO LIFE!</b> There is a risk of the construction personnel falling during assembly or when carrying out repairs. <b>Explanation:</b> Inadequate or insufficient safety measures or errors during the assembly of the Step Over system can lead to falls resulting in severe/fatal injuries.</p>	<ul style="list-style-type: none"> <li>The Step Over system is only to be assembled as specified in the assembly instructions.</li> <li>After assembly or after carrying out repairs, check all structural parts and connecting components to make sure that they are located correctly.</li> <li>Do not install the platform on any surfaces, either internal or external, that are damaged.</li> </ul>
<p><b>DANGER TO LIFE!</b> There is a risk of the Step Over system failing if the installation site is unsatisfactory. <b>Explanation:</b> A non-approved roof surface can result in the Walkway system sliding and falling.</p>	<ul style="list-style-type: none"> <li>Follow the detailed information on the installation sites for the Step Over system in the assembly instructions.</li> <li>The roof surface must always be of the prescribed quality and load-bearing capacity.</li> <li>The prescribed measures must always be complied with.</li> </ul>
<p><b>DANGER TO LIFE!</b> There is a risk of people falling due to failure to carry out maintenance work on the Step Over System. <b>Explanation:</b> Defects or damage can impair the function of the Walkway system therefore the system may possibly not be guaranteed in the event of an emergency.</p>	<ul style="list-style-type: none"> <li>If you have to carry out repairs on the roof or any plant always carry out a visual check on the Step Over system and the roof area beforehand for damage.</li> <li>Any parts that are found to be damaged must always be replaced before any work is started. Only then is it permitted to start the actual work on the roof.</li> </ul>
<p><b>DANGER TO LIFE!</b> There is a risk of people falling due to attaching Personal Protection Equipment to a Step Over system. <b>Explanation:</b> The Walkway system must never be used to attach P.P.E. to an anchor for abseiling or similar work.</p>	<ul style="list-style-type: none"> <li>The Step Over system is a stand-alone, maintenance Walkway system and should always be treated as such. Under no circumstances should the system be used as a "man anchor" or as a connection for P.P.E.</li> </ul>

### 2. INSTRUCTION

Basic safety instructions for the safe handling of the KeeWalk® Step Over system can be found in the KeeWalk® Step Over Instructions for use Manual.



## 10 Step Assembly Instructions



## Start Up Tools

Minimum 2 Users Recommended for Assembly

Level		Socket Wrench	
Tape Measure		Full Set Imperial Allen Keys	
Rubber Mallet		Hex Key Socket Screw Sized 5/16" AF	
Impact Driver		Torque Wrench 8 ft-lb – 45 ft-lb	
Socket Set		Safety Gloves	

## Checking the Step Components

ID 1		ID 2		ID 3	
ID 4		ID 5		ID 6	
ID 7		ID 8		ID 9	
ID 10		ID 11		ID 12-20	
ID 25					

## Table 1 - Components Table

Use Table 1 to identify Parts in Assembly instruction.

NO	FITTING DETAIL	QTY
1	10-8	6
2	21-8	2
3	29-8	6
4	61-8	4
5	SAP-STEP	9
6	45-8	18
7	BC53-88	2
8	133D	18
9	325-8	2
10	326-8	2
11	C50-88	8
12	1-1/2" TUBE @ 49 3/4"	2
13	1-1/2" TUBE @ 128 3/4"	2
14	1-1/2" TUBE @ 106 5/8"	4
15	1-1/2" TUBE @ 105 3/4"	2
16	1-1/2" TUBE @ 77"	2
17	1-1/2" TUBE @ 26"	3
18	1-1/2" TUBE @ 30"	9
19	1-1/2" TUBE @ 42"	2
20	1-1/2" TUBE @ 60"	1
21	1-1/2" TUBE @ 60"	1
22	1-1/2" TUBE @ 60"	1
23	1-1/2" TUBE @ 60"	1
24	1-1/2" TUBE @ 60"	1
25	1-1/2" TUBE @ 60"	1

General Description

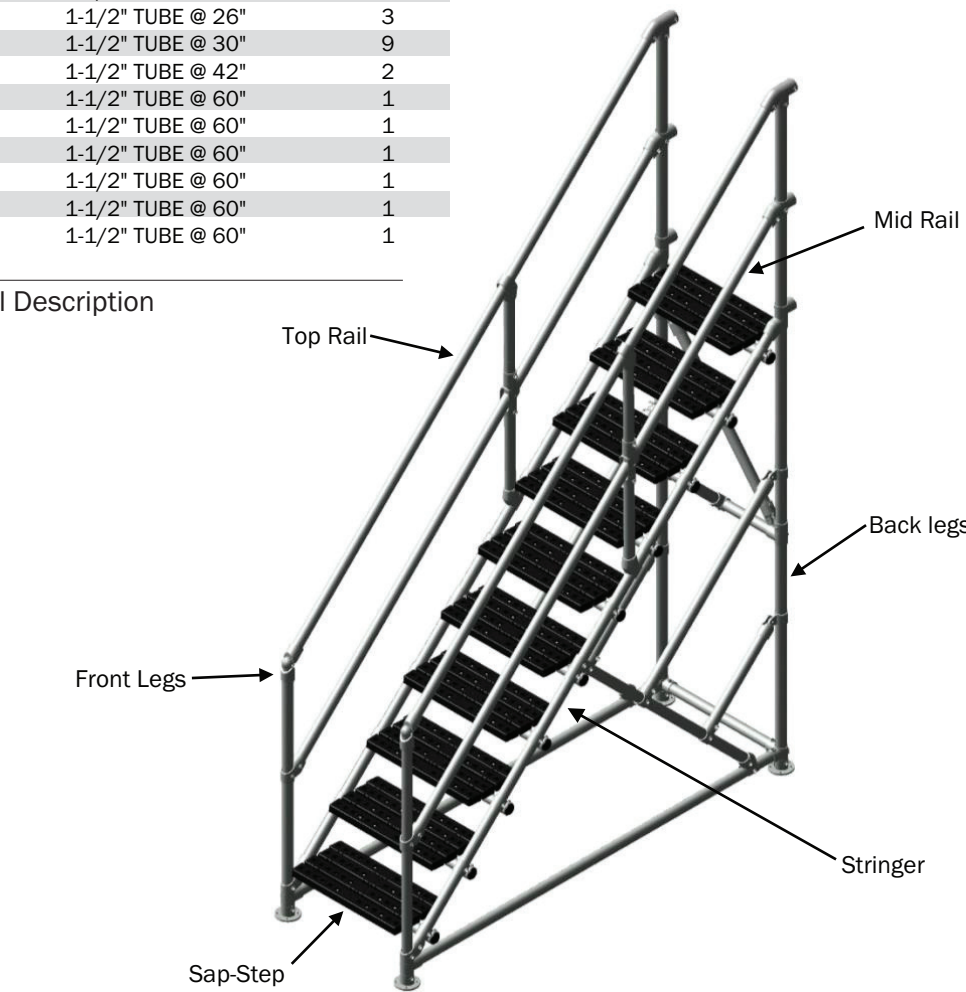

## Table 2 - Step Dimensions

Use Table 2 for Vertical and Horizontal Dimension when Assembling steps

Vertical 'Y'	Dimension	Horizontal 'X'	Dimension
Y1	32"	X1	28"
Y2	89"	X2	87.5/8"
Y3	21-3/8"	X3	10-3/8"
Y4	138-7/8"	X5	3-1/2"
Y5	27-1/8"		
Y6	36-3/4"		

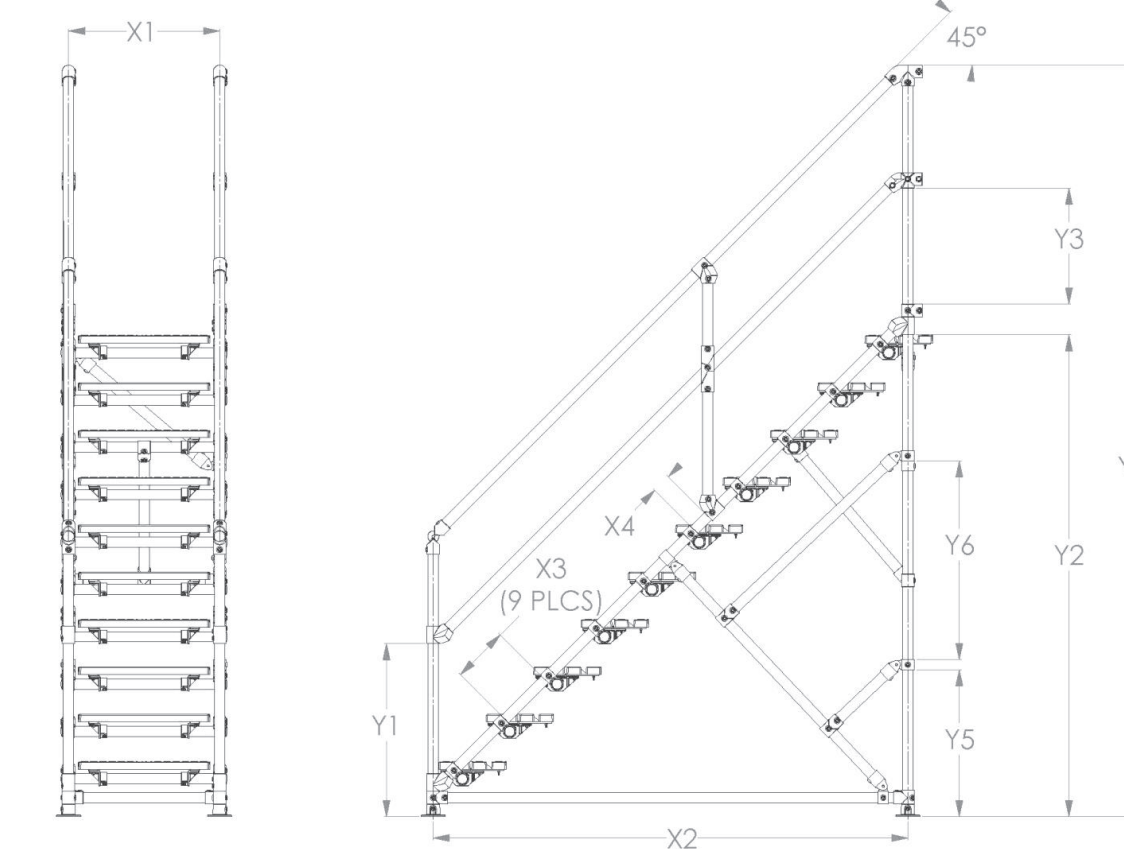

## 1 Assembling the Tread

Assembly 1 – SAP-STEP

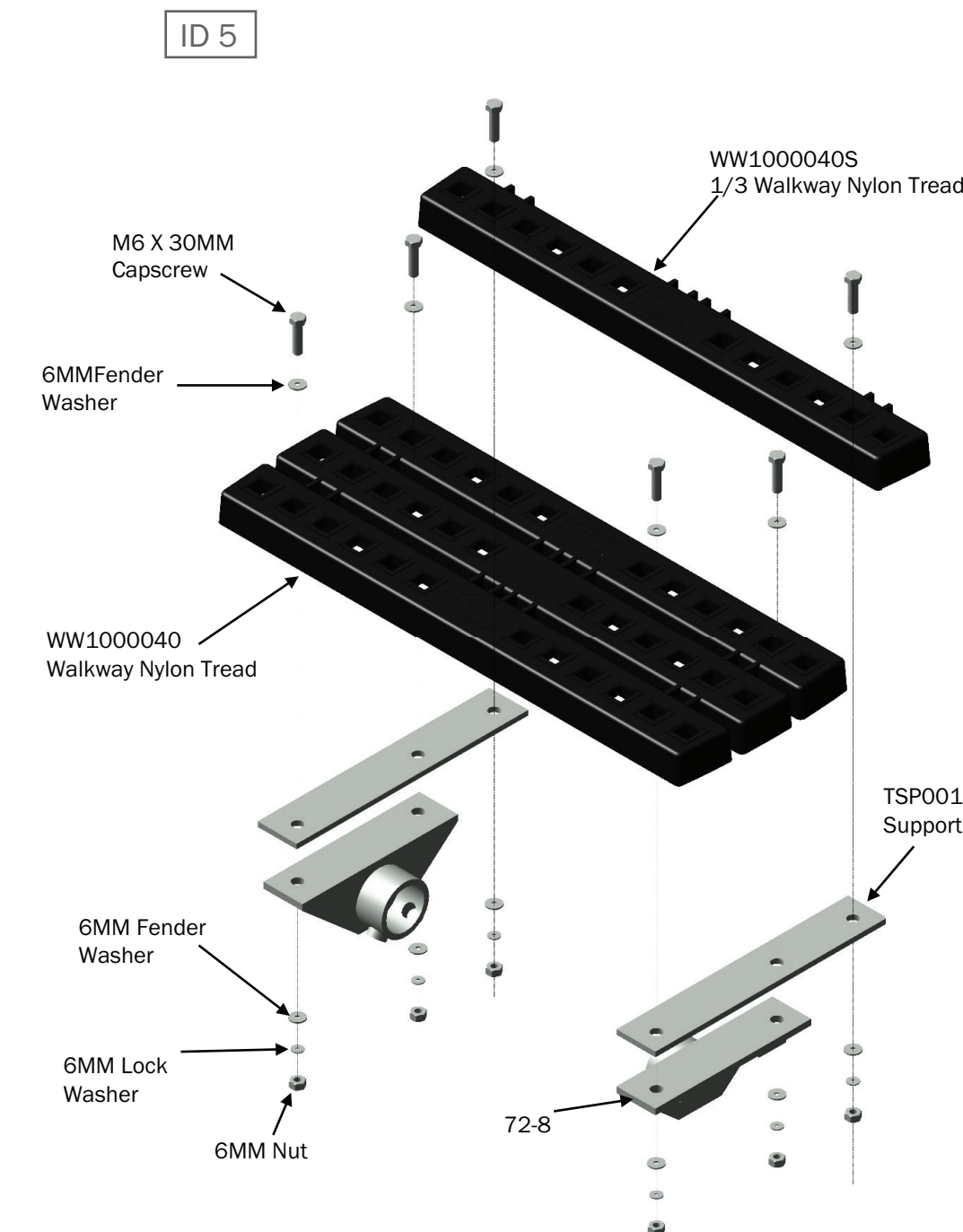

## 2 Assembling the Step

Assembly 2 – Back Legs

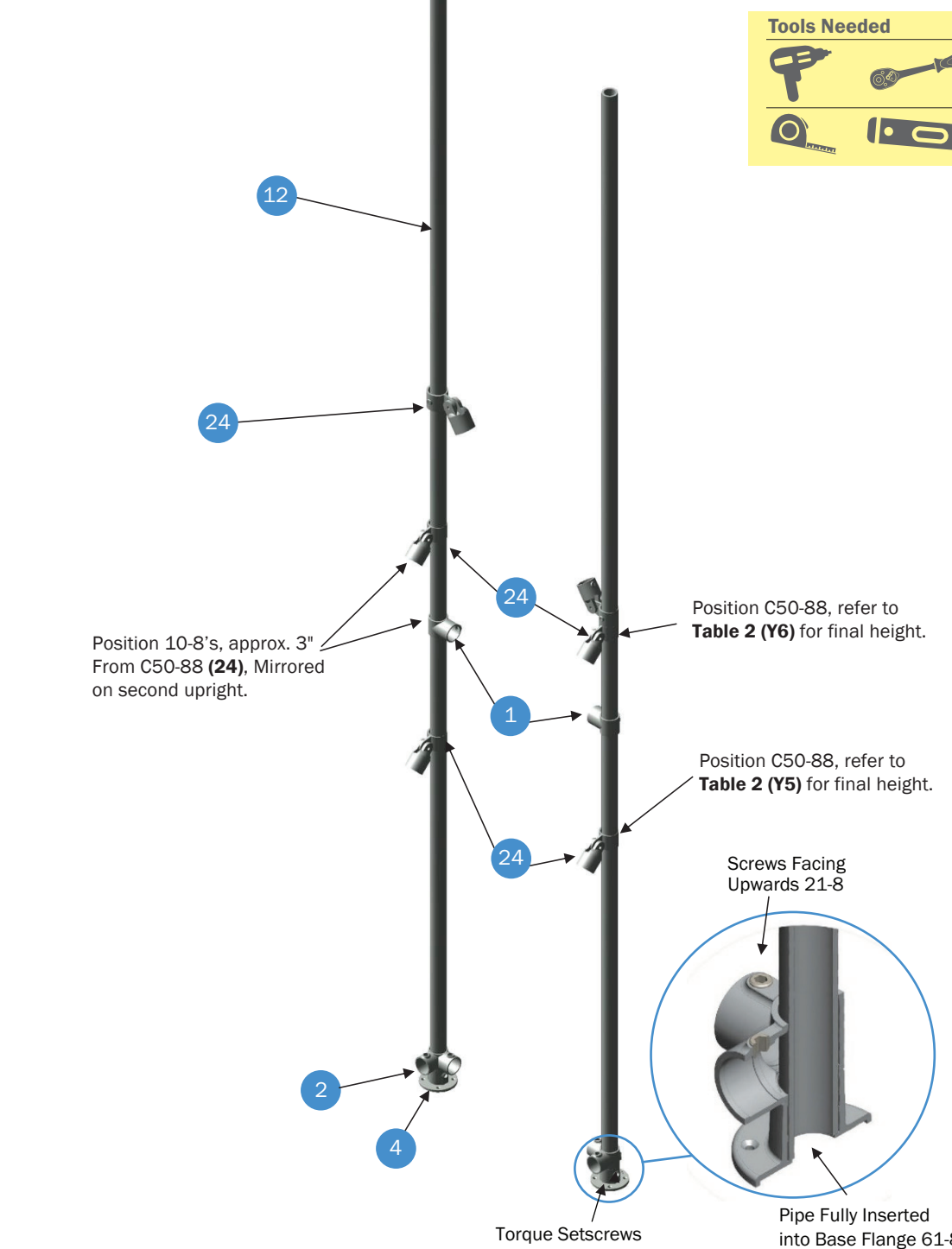

## 3 Assembling the Step

Assembly 3 – Back Legs and Cross Pipes



## 4 Assembling the Step

Assembly 4 – Back Legs Frame

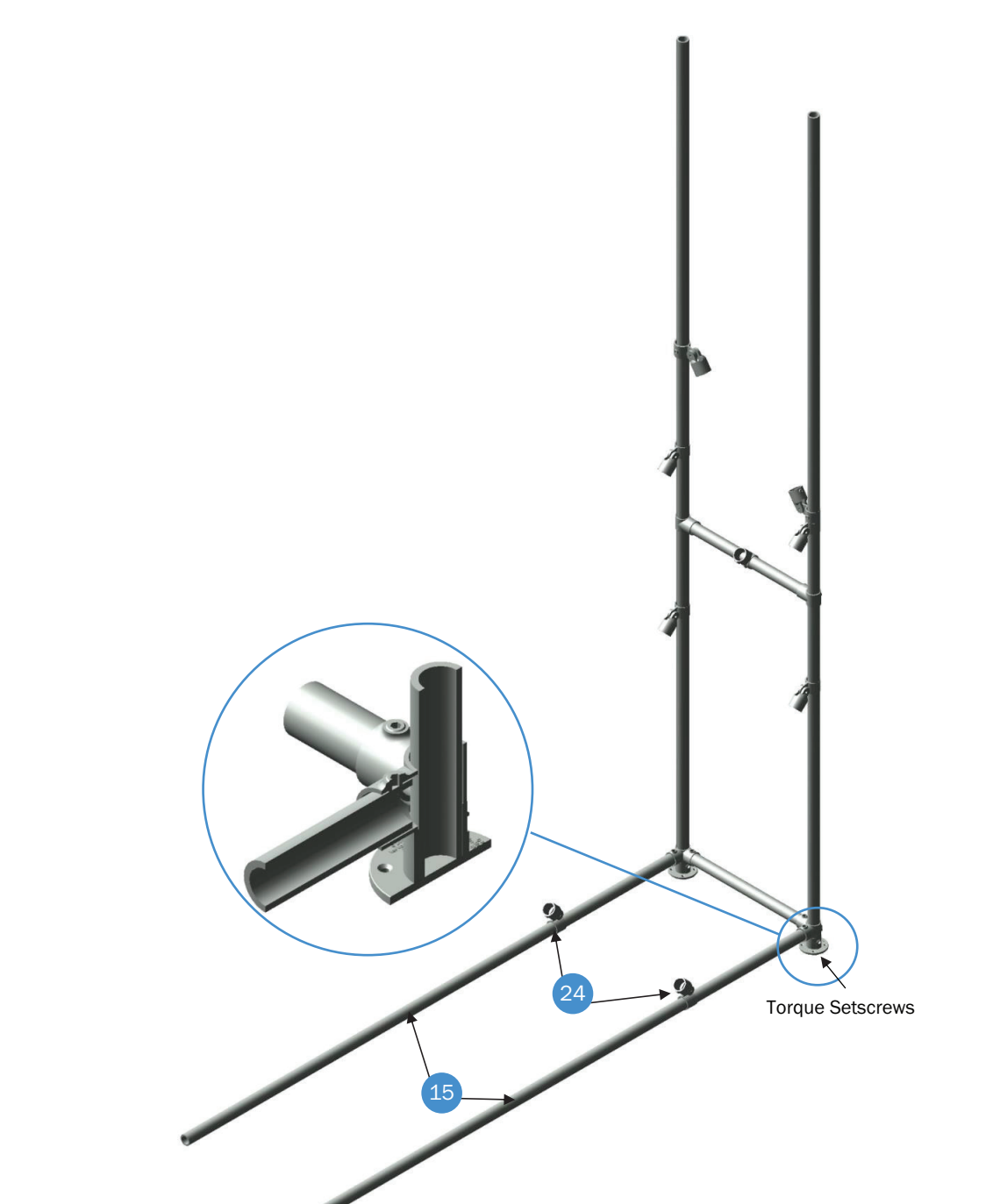

## 5 Assembling the Step

Assembly 5 – Front Legs

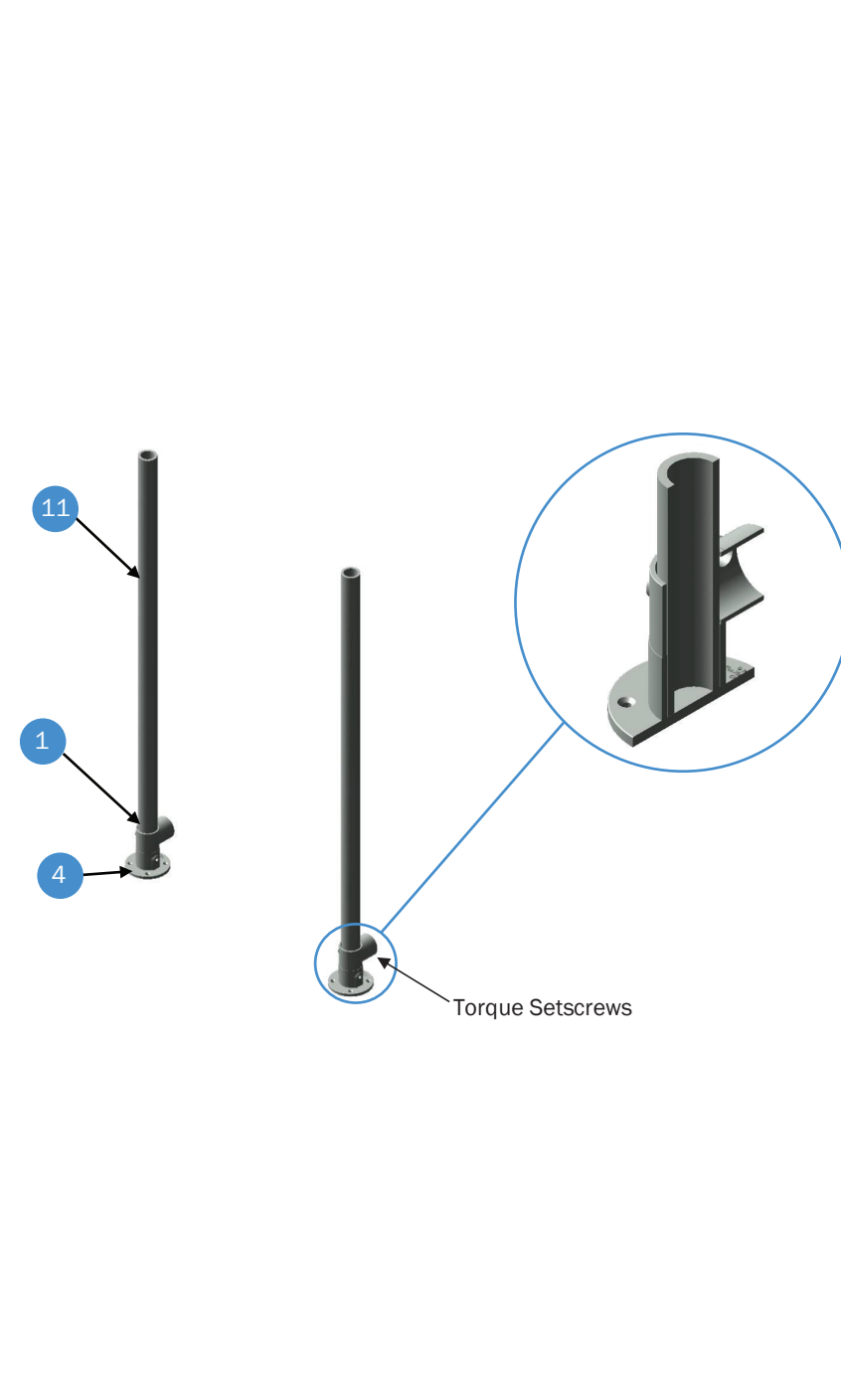

## 6 Assembling the Step

Assembly 6 – Front and Back Leg Assembly

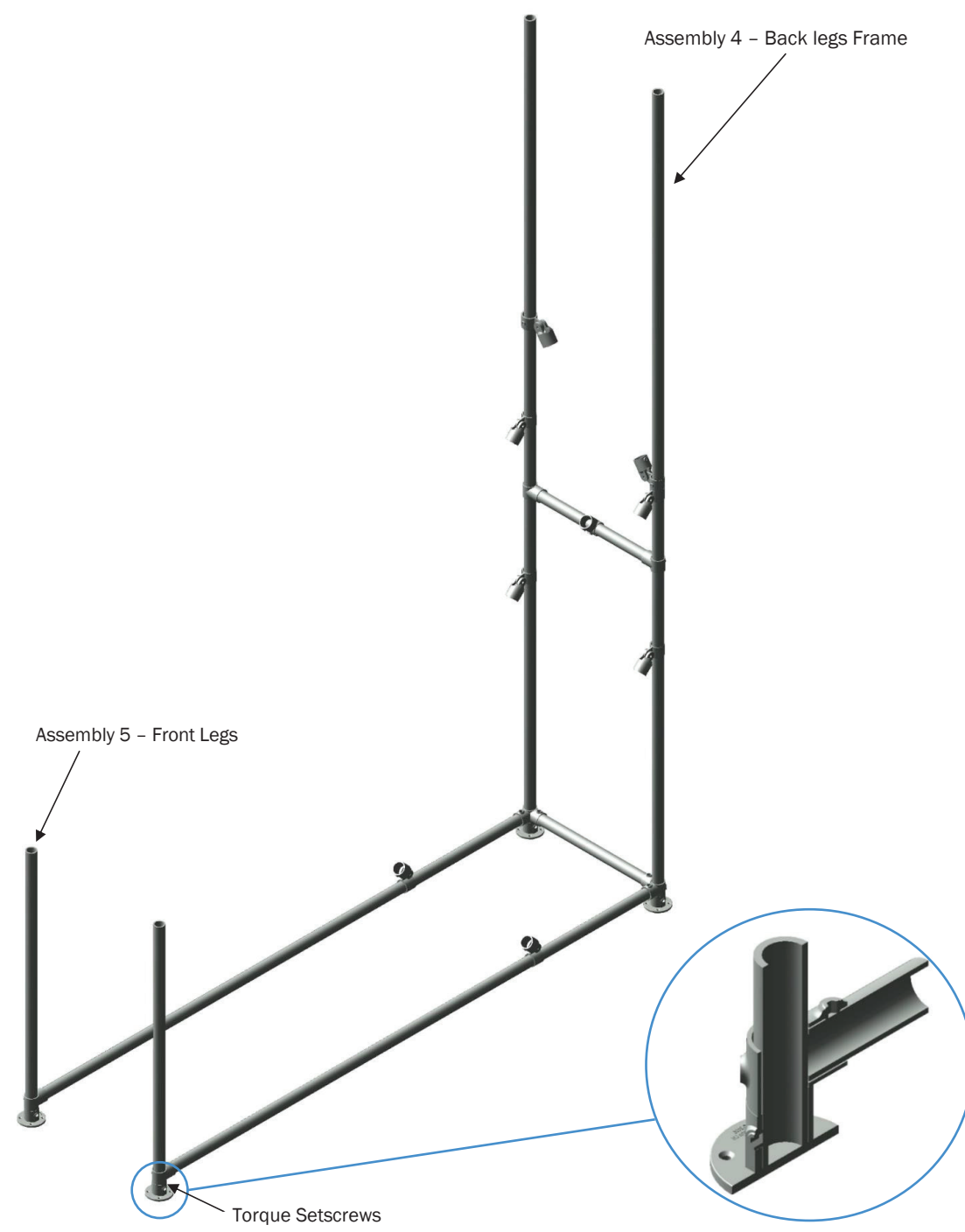

## 7 Assembling the Step

Assembly 7 – Stringer Assembly

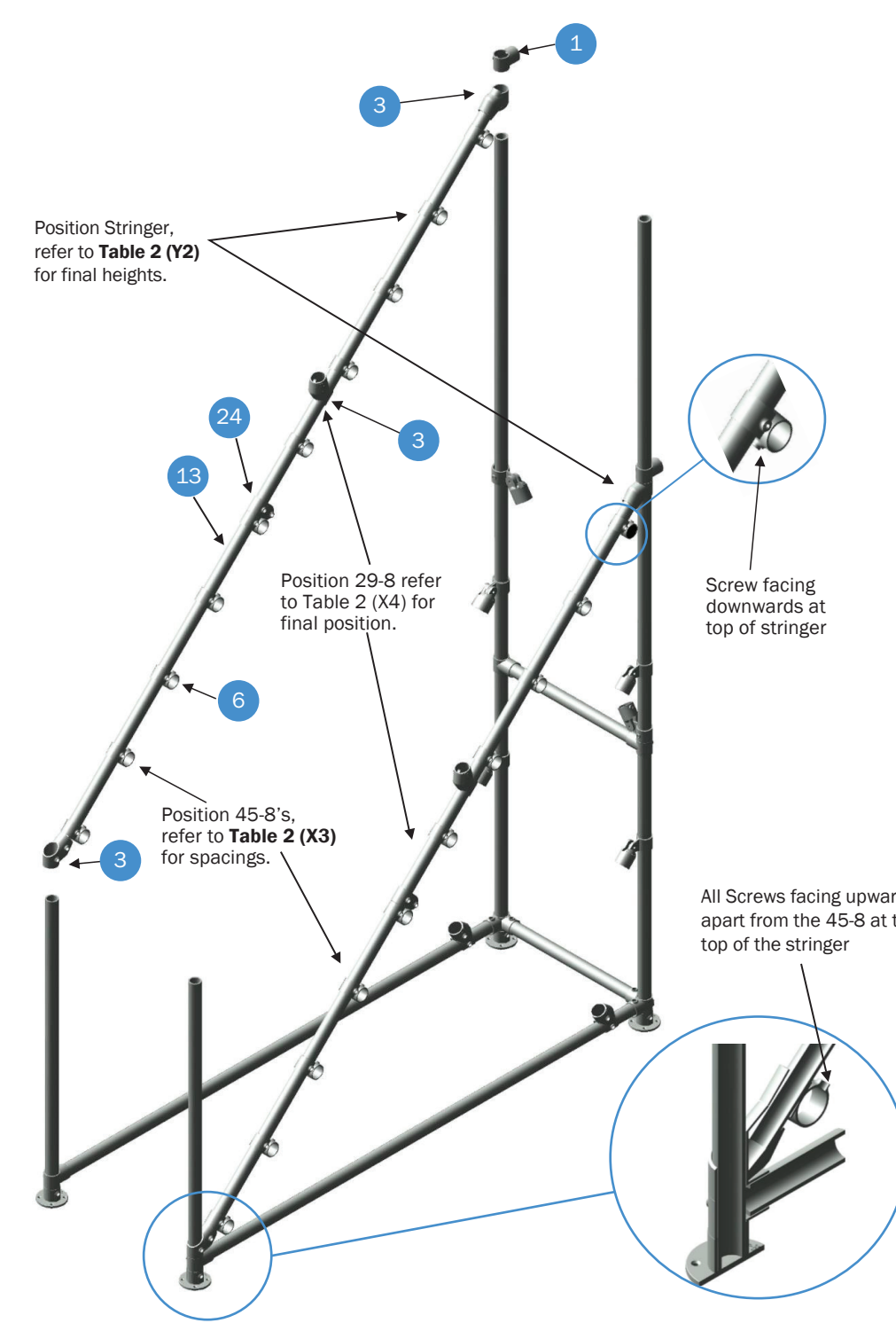

## 8 Assembling the Step

Assembly 8 – Mid Rail Assembly

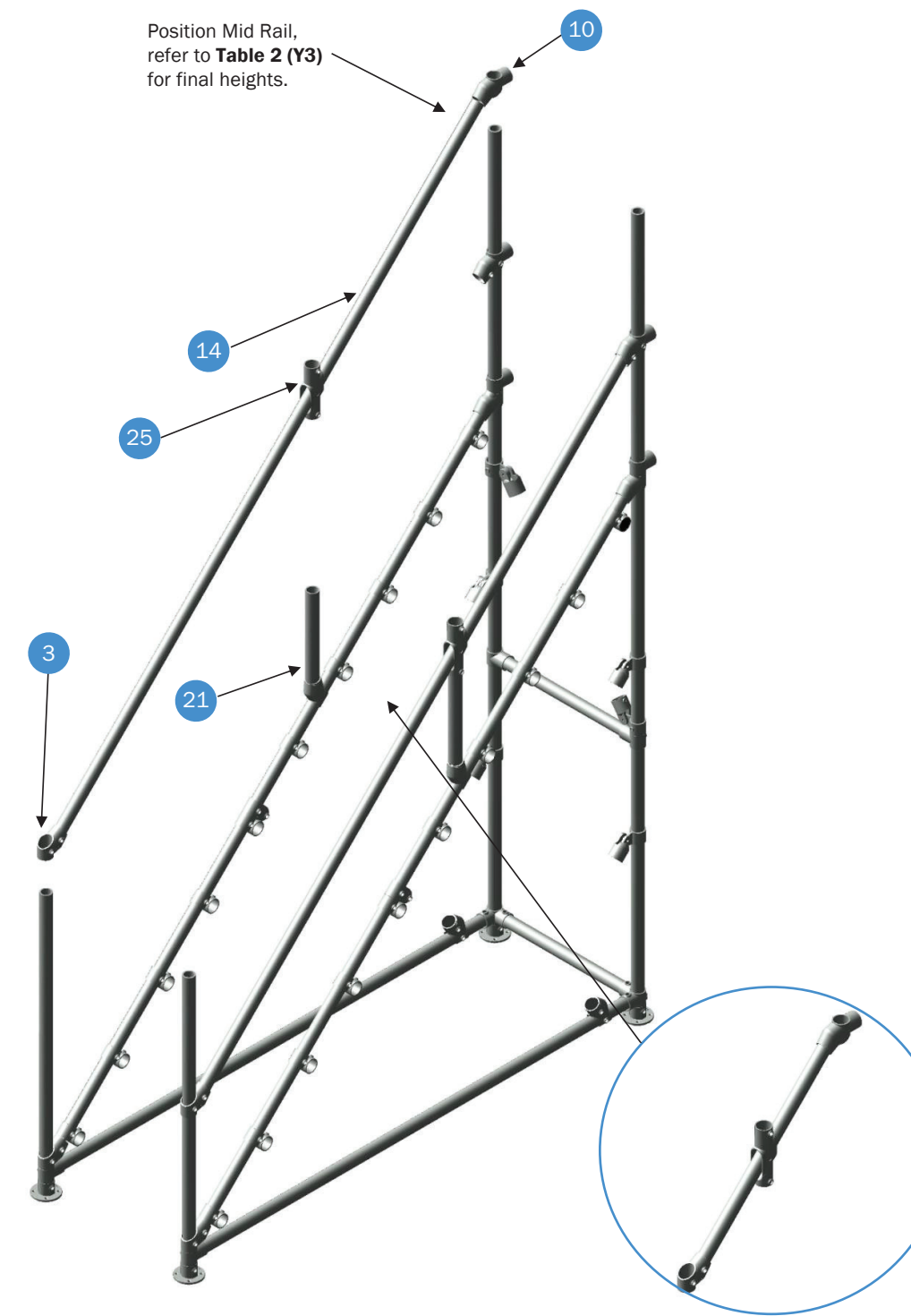

## 9 Assembling the Step

Assembly 9 – Top Rail Assembly

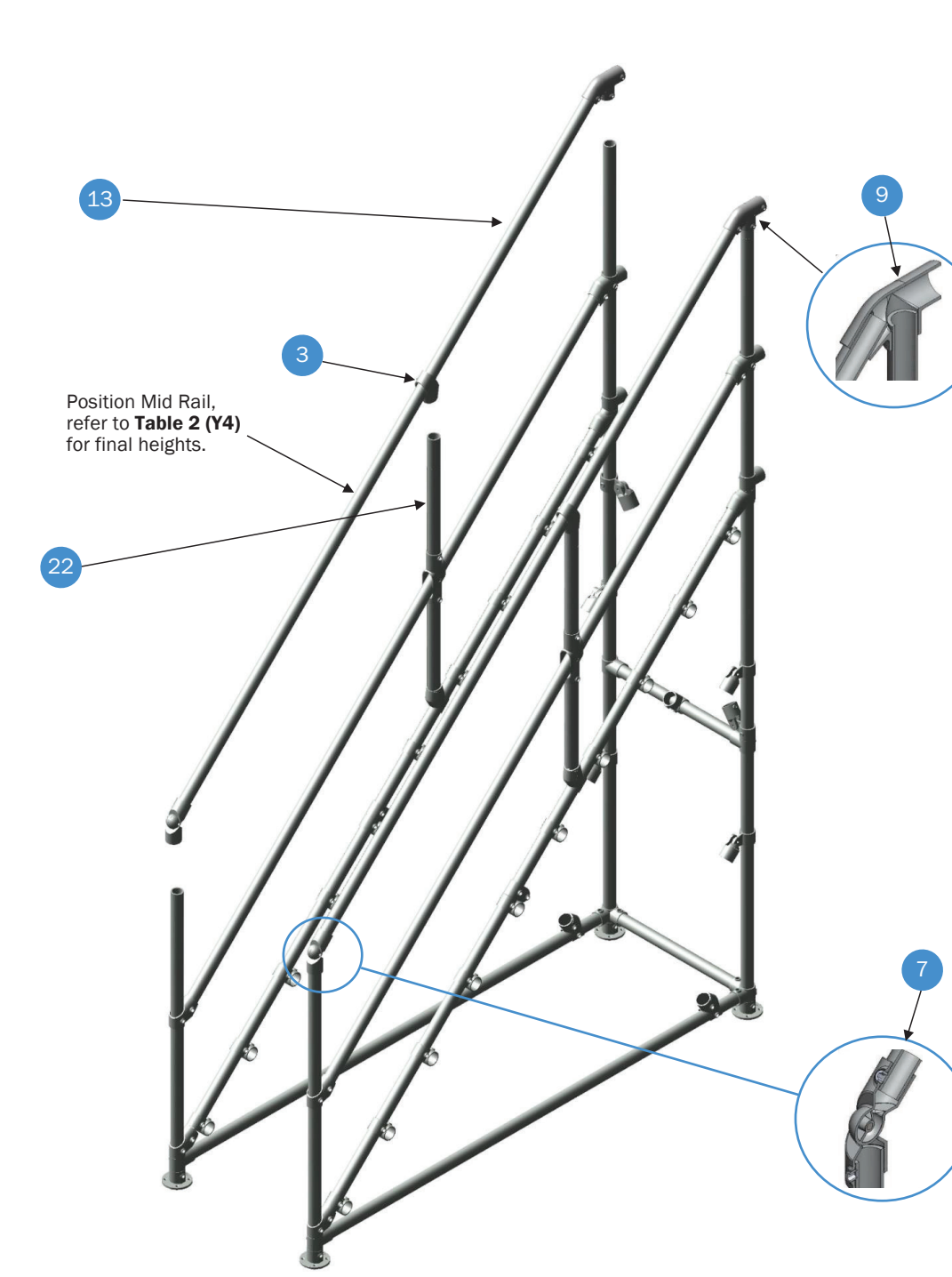

## 10 Assembling the Step

Assembly 10 – Rear Diagonal Assembly

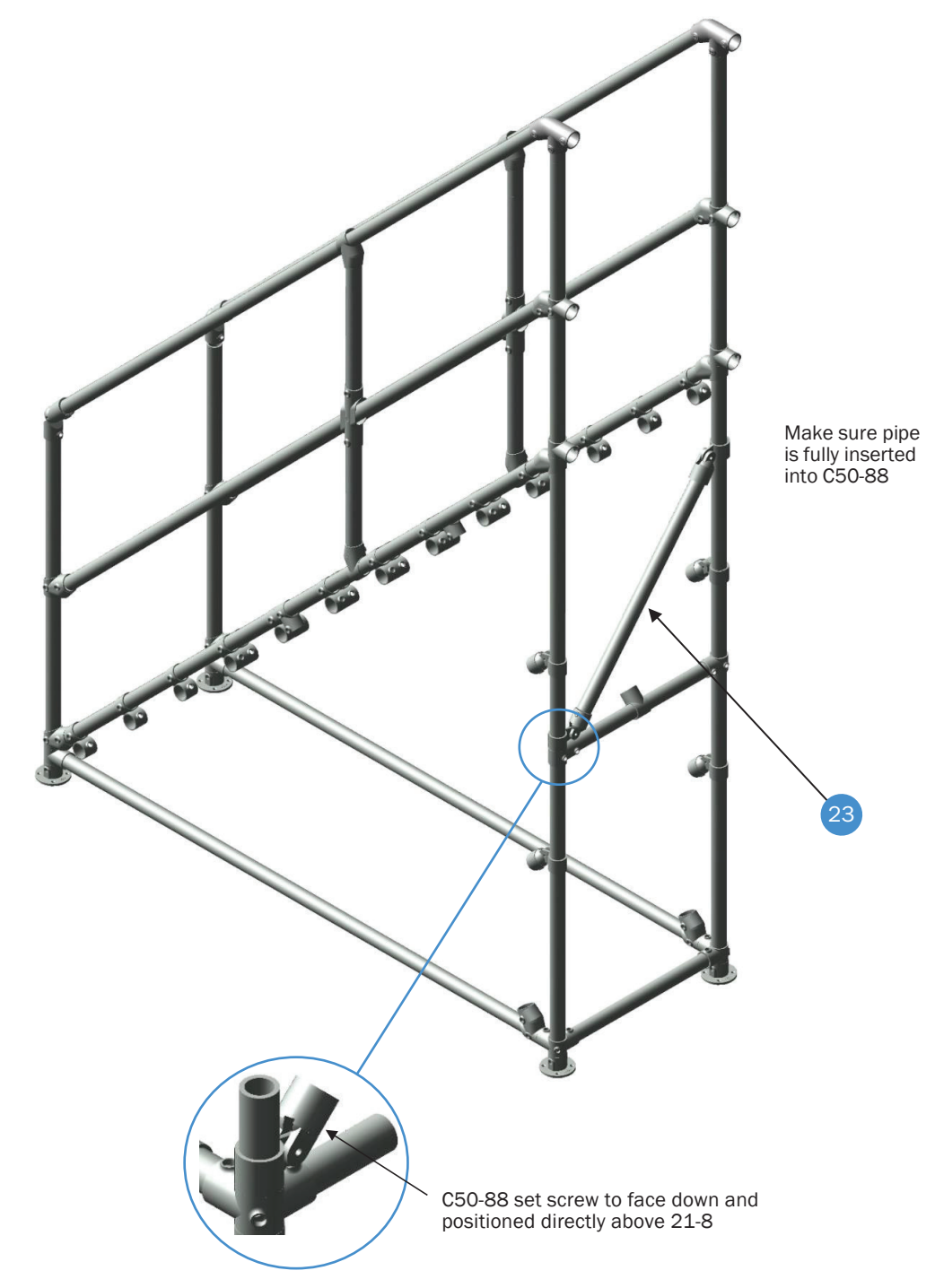

## 11 Assembling the Step

Assembly 11 – Stringer Diagonal Assembly

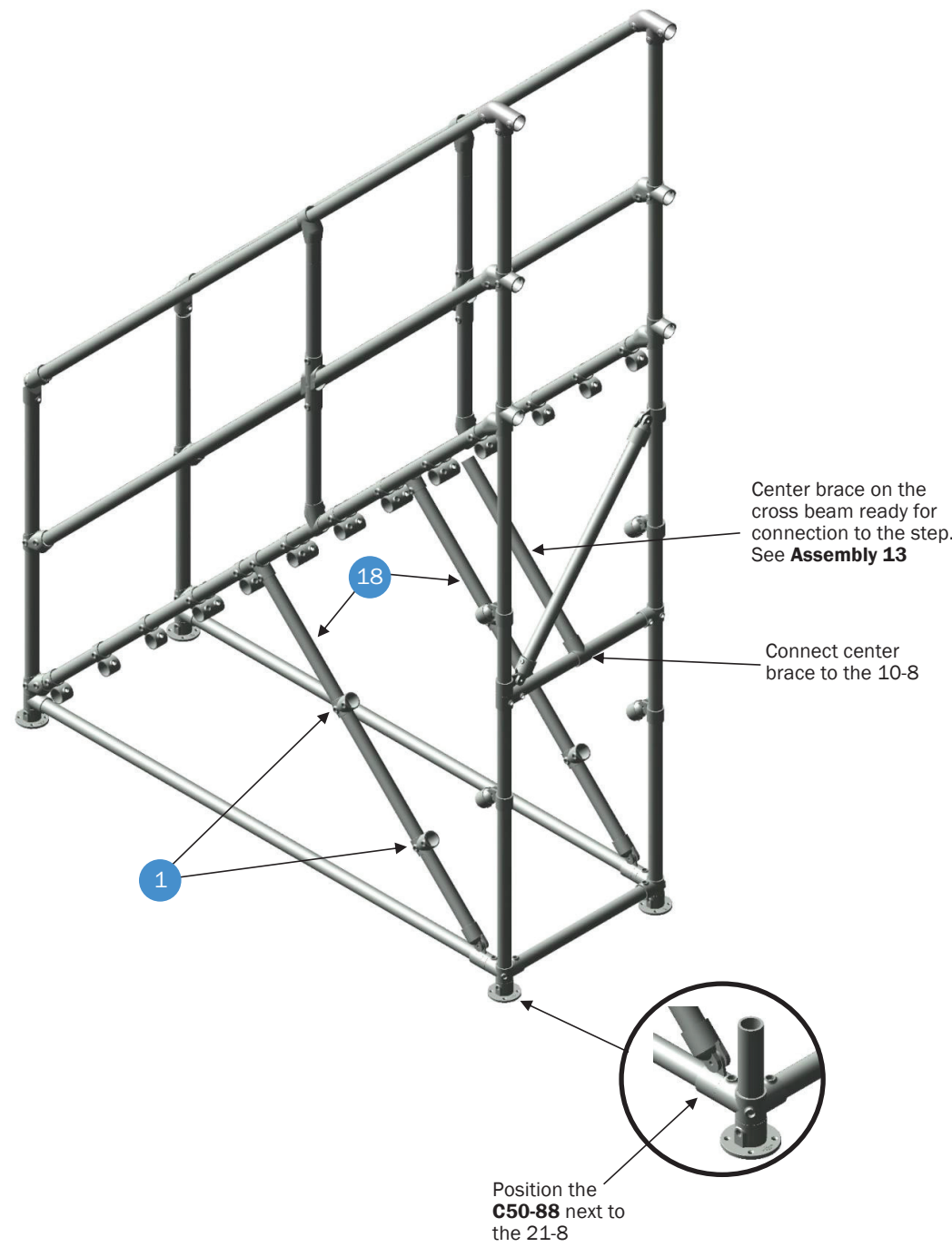

## 12 Assembling the Step

Assembly 12 – Upright Diagonal Assembly

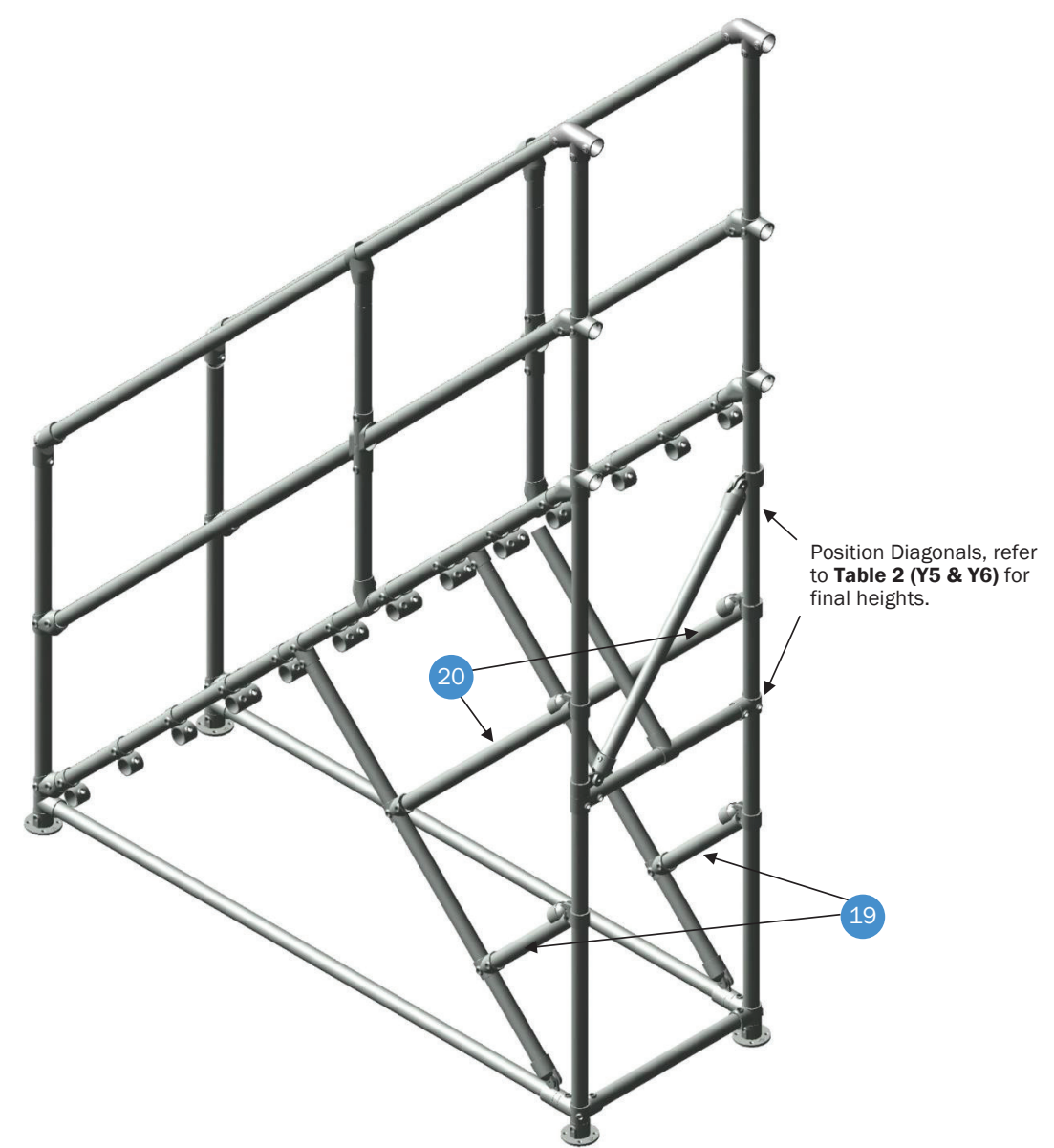

## 13 Assembling the Step

Assembly 13 – SAP Step Assembly

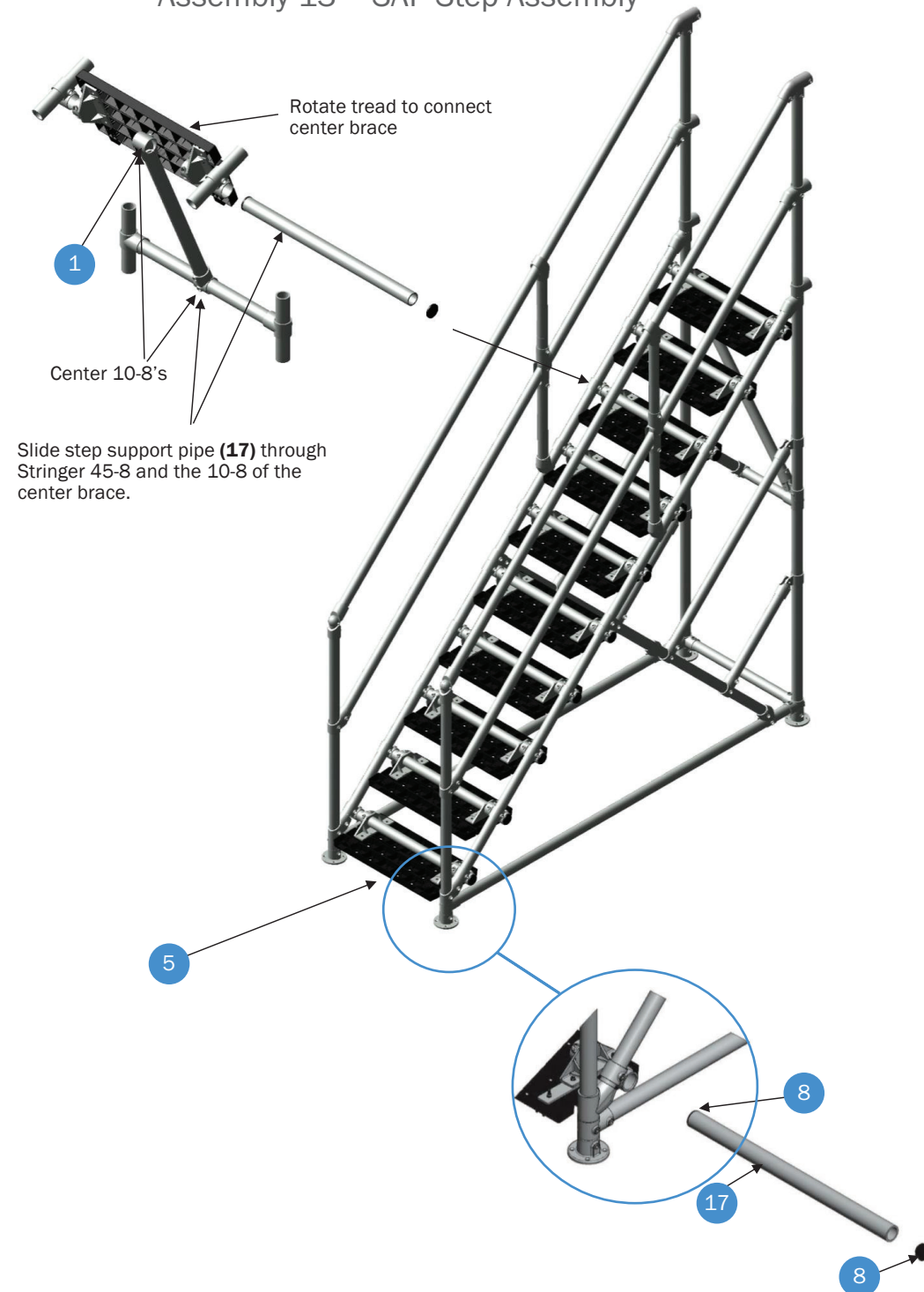

## 14 Assembling the Step

Assembly 14 – Level Steps

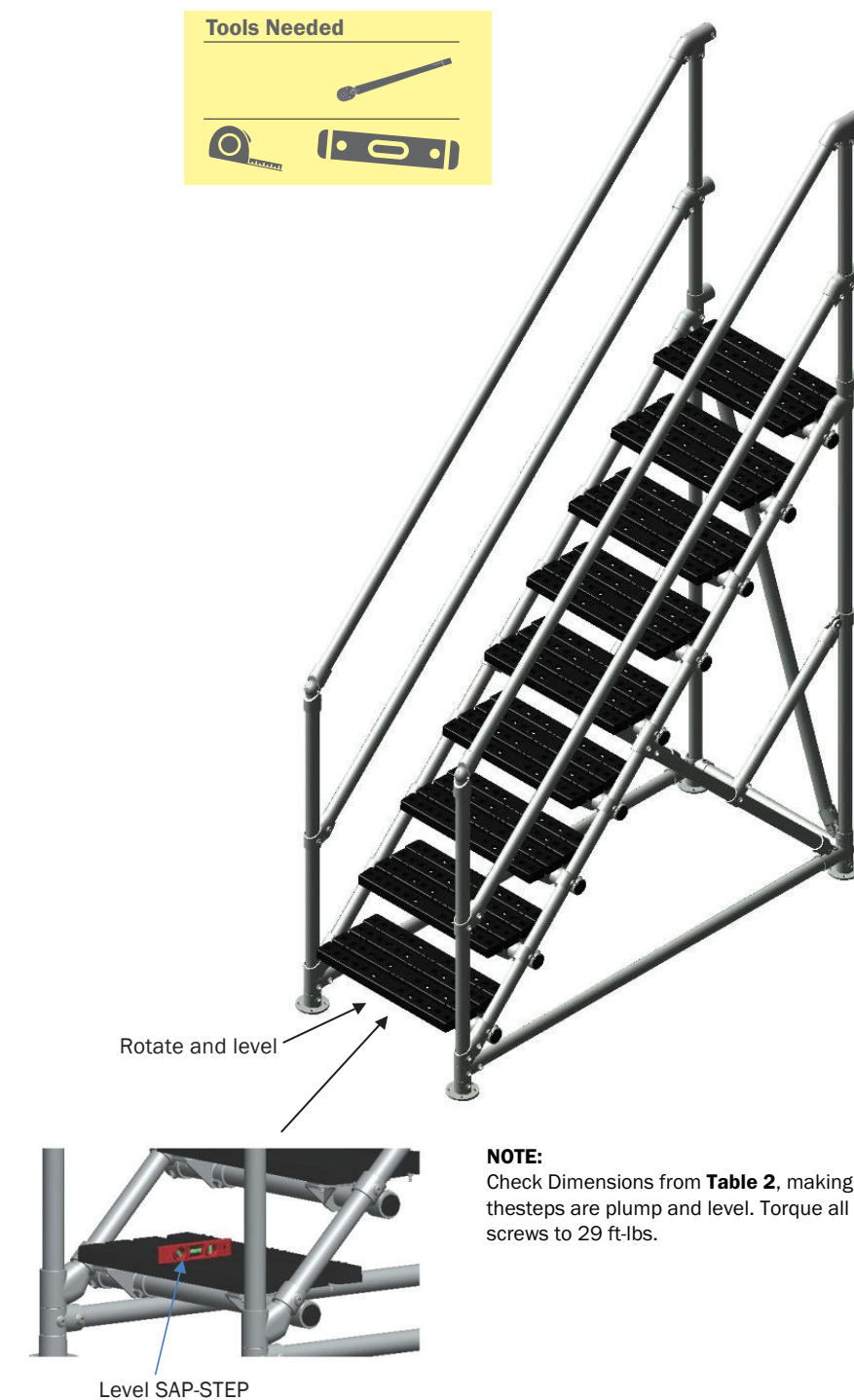

## Step Recertification

- Periodic inspections by a competent person are recommended by the manufacturer. The frequency will depend upon the environment, location and usage but should be at least every 12 months and a visual inspection should be taken before entering the steps.
- Walk and visually inspect the complete installed system in relation to the clients general needs. Establish if any modifications and/or additional products are required to reflect any refurbishment requirements or additional plant & equipment which have been installed and require access.
- Check installation configuration is complete as per the original installation drawing/plan.
- Ensure the system has not been modified or tampered with by unauthorized persons.
- Check all base feet are in contact with the roof.
- Check all grub screws are in place and correctly torqued.
- Check the general height and level of the system including the leg centers and platform overall configuration. (This only tends to be an issue if the system has been tampered with between inspections.)
- Any galvanized components showing signs of corrosion should be wire brushed thoroughly and galvanized spray/paint applied as appropriate. If rusted significantly, take digital photographs, and include these in the inspection report.
- Where applicable check fixings to walls/structures including cat ladder clamps are in place and sufficiently torqued.