



SAFETY AT THE HIGHEST LEVEL

KeeGuard Topfix Operation & Maintenance Manual





COPELLA

Boffano

LABORATORI



SAFETY GUARDRAIL SYSTEMS

The Company's guardrail system KEEGUARD has been designed specifically to provide permanent edge protection for areas where regular access for maintenance and inspection is required.

UNIQUE SYSTEMS

Each system's unique design provides permanent edge protection without the need to mechanically fix the system through the roofing membrane or building's structure. Their simple cantilever principle provides unrivalled strength, stability and safety and overcomes the problems associated with traditional systems such as having to drill and puncture the roof membrane which can lead to potential penetrative water damage and noise disturbance during installation. Similarly, high levels of insulation included within warm deck and inverted flat roof designs often mean it is virtually impossible to fix through, as with traditional systems, without causing cold bridging. This may then cause interstitial condensation to form within the flat roof construction, causing the roof to deteriorate and eventually require replacement. When it is not appropriate to use counter balanced systems, such as modern industrial cladded pitched roofs, KeeGuard Topfix may be an alternative to traditionally fixed systems.



DURABLE SYSTEMS

The Company's guardrail connections are supplied with a galvanised finish carried out to BS EN ISO 1461 and ASTM A53: Hot Dip Galvanised Coatings Specification and Testing Methods, giving an average coating of between 65-85 microns. All products are also available in aluminium. All cast clamps have Threadcoat applied to all tapped holes. All grub screws are carbon steel and have Keekoat protection applied to ensure minimal maintenance.

COMPONENT BASED SYSTEMS

All systems consist of galvanised/aluminium tubing joined together using the KEE KLAMP method of connection. KEEGUARD, raked, radiused and folding systems' base feet connect to the 100% recycled PVC counter weight, giving the system its strength & stability.



VERSATILE SYSTEMS

All systems have been specially designed to fit any shape and size of flat and pitched roofs, even circular designs. The systems can also cope with changes in levels, roof falls and difficult details such as ductwork passing over the roof edge and cable trays/plant mounted at the roof edge. The flexibility of the counter weight & KEE KLAMP design allows the systems to be used on plant congested or complex detailed roofs. The product range has been extended to suit specific requirements and includes the standard design with vertical legs, raked and radiused systems, as well as a folding version for areas where a more discreet form of protection is required. KeeGuard Topfix has also been added to the range to provide collective protection solutions for industrial cladded pitched roofs.



MEMBRANE PROTECTION SYSTEMS

Each system is installed with rubber matting bonded to the underside of metal components which come into contact with the roof membrane. In some cases the counter weight and base foot have sacrificial pads placed between the edge protection components and the roof membrane. This protects the roof membrane from damage via heat transfer or direct contact with components. On warm deck roof construction specifications pedestrian tiles are recommended to be placed where base feet and counter weights are in contact with the roof membrane. Where KeeGuard Topfix is installed a butyl strip is used where the Base Plates are fixed, via rivets, to the roof cladding.

TESTING & CERTIFICATION

Tested in accordance with:-

- EN 13374 Class A.
- BS 13700, Permanent counterweighted guardrail systems – Specification
- EN ISO 14122 Part 3.
- NF E85-003
- EN 1991-1-4
- BS 6399 : Part 2 Code of Practice for Wind Load.

WIND CALCULATED

Wind loading is the most likely regular and demanding force a free standing roof guardrail will encounter during its lifetime. The Company has developed a computerised programme to calculate the design to ensure compliance with the relevant wind loadings relating to the topography, height and location of the project throughout the World.

OFFICIAL DOCUMENTATION

All Systems comply with the following:-
 Work at Height Regulations.
 HSG 33 “Health & Safety in Roof work”
 HSE Construction Sheet No. 21 “Working on flat roofs protection against falls.”
 European Union Directives together with requirements of CDM Regulations.

AESTHETICS

The smooth lines of the standard galvanised/aluminium finish can be further enhanced by the application of powder coating to BS 6497 Specification for Powder Organic Coatings, EU Codes with bespoke colour produced to special order. Counter weights are available in black or other colours at an additional cost. Where a more discreet form of protection is required, raked and radiused systems, as well as a folding version are welcomed by Planning Officers due to their improved aesthetics.

SYSTEMS DISTRIBUTORS

All systems are available as a supply and installation service or component supply only. Products are available from The Company directly or one of its licensed distributors.

INDUSTRIAL CLADDED ROOFS

The Company has developed a new collective roof edge protection system, KeeGuard Topfix specifically for metal profile and standing seam roofs up to 45°. Pitched cladded roofs have traditionally been protected using personal fall protection systems which are lower in the hierarchy of controls.

PRODUCT SPECIFICATION

FEATURES :-Metal Cladded Roof System.

GENERAL

KeeGuard® Topfix system is fixed to the cladding panel via a base plate for metal roofs. This is either riveted or connected to the cladding panel via standing seam clamps. The complete system's design, manufacture, testing and installation has been externally assessed and tested to EN 13374 & BS 13700.

MATERIALS

Steel tubing to BS EN 10255 - 2.9mm
 All steel components galvanised to BS EN 10240.
 Guardrail top and intermediate rails are produced in steel - 48.3mm external diameter (Wall thickness 2.9mm).
 The vertical support legs are produced in steel - 48.3mm external diameter (Wall thickness 2.9mm).
 All cast clamps have Threadcoat applied to all tapped holes. All grub screws are carbon steel and have Keekoat protection applied to ensure minimal maintenance.
 All cast clamps used to join the guardrail are galvanised malleable cast iron produced to BS EN 1562 : founding malleable cast iron.
 Where tubing is cut on site, zinc rich paint is applied to the cut end of the tube.
 Base plate metal roofs are galvanised steel to BS EN ISO 1461.
 Metal roof panels with minimum steel thickness 0.7mm require 2 rivets per corner.
 Includes butyl sealing strip to maintain the roof's integrity (TA-SEAL 15m roll)
 Fixing centres: 400, 500, 333, 310.
 Composite roof panels with minimum steel thickness 0.5mm thick require 4 rivets per corner.
 Includes butyl sealing strip to maintain roof's integrity (TA-SEAL 15m roll) Fixing centres: 333 mm

STANDING SEAM ROOFS

Designed to clamp on to the standing seam of a proprietary roofing sheet. Fixed with non penetrative WFP6 clamps Fixing centres: 305, 400, 500mm WFP6 (4 per pkt) Standing seam clamps – WFP6 material : Galvanised steel to BS EN ISO 1461. Rivets material : Aluminium.
 Sealing strip:- This is to form a seal between the underside of the plate and the metal decking. Material : Butyl.

LAYOUT

Height of guardrail is set at 1100mm.
 All vertical supports are set at a maximum 3m centres depending on the system used.

TESTING

All systems have been tested to EN 13374: Temporary Edge Protection Systems - Product Specification Test Methods and have been awarded a Class A Pass. All systems have been tested to BS 13700: Permanent counterweighted guardrail systems – Specification and been awarded a pass.

WIND LOADING

All installations are wind speed calculated to BS 6399 : Part 2 : Code of Practice for Wind Loads.



EN 13374 & BS 13700

Roof Type	MAX Pitch	Tube Size	Tube Thickness	MAXIMUM BAY CENTRES	
				First/End Bay Length	Subsequent Bay Lengths
Metal Cladded Roofing system					
Restrained	10°	8	2.9mm	3m	3m

Kee Safety **ROOF EDGE PROTECTION**
 SEPARATING PEOPLE FROM HAZARDS

- THIS GUARDRAIL IS TESTED TO EN 13374/EN 14122-3
- THIS GUARDRAIL IS TESTED TO BS 13700: PERMANENT COUNTERWEIGHTED GUARDRAIL SYSTEMS- SPECIFICATION
- DO NOT REMOVE, TAMPER, ADJUST, REMOVE OR ALTER IN ANY WAY THE GUARDRAIL INSTALLATION WITHOUT FIRST CONSULTING KEE SAFETY.
- NO LANYARD LIFE LINE OR FALL ARREST PRODUCTS TO BE ATTACHED TO THE GUARDRAIL AT ANY TIME
- DO NOT ATTACH PLASTIC SHEETING OR ANYTHING THAT WOULD INCREASE THE WIND LOADING ON THE GUARDRAIL
- IF YOU FIND THE GUARDRAIL HAS BEEN ALTERED OR TAMPERED WITH, CONTACT KEE SAFETY IMMEDIATELY

HEAD OFFICE
 Kee Safety Limited
 Cradley Business Park
 Overend Road
 Cradley Heath
 West Midlands B64 7DW

(t) +44 (0) 1384 632 188
 (f) +44 (0) 1384 632 152
 (e) info@keesafety.co.uk
 (w) www.keesafety.co.uk

• RE-TEST ONLY TO BE CARRIED OUT BY AUTHORISED SERVICE AGENT.

SYSTEM PLAQUE - SL 111

Provides details of the system and approvals.
 Material : Plastic.
 Net weight : 0.085kg.

PRODUCT SPECIFICATION EN 14122-3 & NF E85-003

FEATURES :- Metal Cladded Roof System.

GENERAL

KeeGuard® Topfix system is fixed to the cladding panel via a base plate for metal roofs. This is either riveted or connected to the cladding panel via standing seam clamps. The complete system's design, manufacture, testing and installation has been externally assessed and tested to EN 14122-3

MATERIALS

Steel tubing to EN 10255 - 3.2mm

All steel components galvanised to BS EN 10240.

Guardrail top and intermediate rails are produced in steel - 48.3mm external diameter (Wall thickness 3.2mm).

The vertical support legs are produced in steel - 48.3mm external diameter (Wall thickness 4.0mm)

All cast clamps have Threadcoat applied to all tapped holes. All grub screws are carbon steel and have Keekoat protection applied to ensure minimal maintenance.

All cast clamps used to join the guardrail are galvanised malleable cast iron produced to BS EN 1562 : founding malleable cast iron.

Where tubing is cut on site, zinc rich paint is applied to the cut end of the tube. Base plate metal roofs are galvanised steel to BS EN ISO 1461.

Metal roof panels with minimum steel thickness 0.7mm require 2 rivets per corner.

Includes butyl sealing strip to maintain the roof's integrity (TA-SEAL 15m roll) Fixing centres: 400, 500, 333, 310. Composite roof panels with minimum steel thickness 0.5mm thick require 4 rivets per corner.

STANDING SEAM ROOFS

Designed to clamp on to the standing seam of a proprietary roofing sheet. Fixed with non penetrative WFP6 clamps Fixing centres: 305, 400, 500mm WFP6 (4 per pkt) Standing seam clamps – WFP6 material : Galvanised steel to BS EN ISO 1461. Rivets material : Aluminium.

Sealing strip:- This is to form a seal between the underside of the plate and the metal decking. Material : Butyl.

LAYOUT

Height of guardrail is set at 1100mm.

First bay maximum span 1.75m

Subsequent bays 2.5m

All vertical supports are set at a maximum 3m centres depending on the system used.

TESTING

All systems have been tested to EN 14122-3 & NF E85-003

WIND LOADING

All installations are wind speed calculated to BS 6399 : Part 2 : Code of Practice for Wind Loads.

All installations are wind speed calculated to Eurocode 1: Actions on structures - Part 1-4: General actions - Wind loads



EN 14122-3 & NF E85-003

Roof Type	MAX Pitch	Tube Size	Tube Thickness	MAXIMUM BAY CENTRES	
				First/End Bay Length	Subsequent Bay Lengths
<i>Metal Cladded Roofing system</i>					
Restrained	10°	8	3.2mm	1.75m	2.5m

PRODUCT SPECIFICATION – USA & Canada

FEATURES:- Metal Cladded Roof System.

GENERAL

KeeGuard® Topfix system is fixed to the cladding panel via a base plate for metal roofs. This is either riveted or connected to the cladding panel via standing seam clamps. The complete system's design, manufacture, testing and installation has been externally assessed.

TESTING

All systems have been tested to:-

OSHA Reg 29 CFR 1910.23 (E) (1); (E) (3) (IV).

OSHA Reg 29 CFR 1926.501 (b) (1); (b) (2) (ii)

OSHA Reg 29 CFR 1926.502 (B) (1) - (B) (14)

Canadian National Building Code 4.1.10.1(1)(e), 4.1.10.1(2), 4.1.10.1(4)

Ontario Building Code Section 4.1.10.1(1)(b), 4.1.10.1(2), 4.1.10.1(4)

California Building Code 1710A.3.1 (24 hour 400lbs point load)

California Code of Regs Title 8 Sections 3209 & 3294

MATERIALS

Gatorshield Tubing

Base Metal: ASTM A-500 Carbon Steel.

Zinc Spelter - ASTM B-6 High Grade Special High Grade Zinc.

Chemical Composition - ASTM A-500.

Material Testing -ASTM-500 and ASTM E-8.

Guardrail top and intermediate rails are produced in steel - 1.9" external diameter (Wall thickness 0.109").

The vertical support legs are produced in steel - 1.9" external diameter (Wall thickness 0.109").

Cantilever tubes are produced in steel - 1.66" external diameter (Wall thickness 0.109").

All cast clamps have Threadcoat applied to all tapped holes. All grub screws are carbon steel and have Keekoat protection applied to ensure minimal maintenance.

All cast clamps used to join the guardrail are galvanised malleable cast iron produced to ASTM A47-77-32510.

Where tubing is cut on site zinc rich paint is applied to the cut end of the tube.

Base plate metal roofs are galvanised steel to ASTM A53 & A153.

Metal roof panels with minimum steel thickness 0.0275" (1/32) require 2 rivets per corner.

Includes butyl sealing strip to maintain the roof's integrity (TA-SEAL 49' roll) Fixing centres: 16", 18", 20.86", 24". Composite roof panels with minimum steel thickness 0.0197" (1/64) thick require 4 rivets per corner. Includes butyl sealing strip to maintain roof's integrity (TA-SEAL 49' roll) Fixing centres: 12" or 14.56"

STANDING SEAM ROOFS

Designed to clamp on to the standing seam of a proprietary roofing sheet. Fixed with non penetrative WFP6 clamps Fixing centres: 25" WFP6 (4 per pkt) Standing seam clamps – WFP6 material : Galvanised steel to ASTM A53 & A153. Rivets material : Aluminium. Sealing strip:- This is to form a seal between the underside of the plate and the metal decking. Material : Butyl.

LAYOUT

Height of guardrail is set at 42". All vertical supports are set at maximum 8'centres.

WIND LOADING

All installations are wind speed calculated to ASCE7 - The American Society of Civil Engineers design standard: "Minimum Design Loads for Buildings and Other Structures"



USA & Canada

Roof Type	MAX Pitch	Tube Size	Tube Thickness	MAXIMUM BAY CENTRES	
				First/End Bay Length	Subsequent Bay Lengths
Metal Cladded Roofing system					
Restrained	10°	8	0.109"	8"	8'

USA & Canada

Roof Type	MAX Pitch	Tube Size	Tube Thickness	MAXIMUM BAY CENTRES	
				First/End Bay Length	Subsequent Bay Lengths
Metal Cladded Roofing system					
Restrained	5°	8	0.109"	3' 3"	6'6"

ROOF EDGE PROTECTION
SEPARATING PEOPLE FROM HAZARDS

HEAD OFFICE
Kee Safety Limited
Cradley Business Park
Owens Road
Cradley Heath
West Midlands B64 7DW

(t) +44 (0) 1384 632 188
(f) +44 (0) 1384 632 192
(e) info@keesafety.co.uk
(w) www.keesafety.co.uk

- THIS GUARDRAIL IS TESTED TO OSHA & OBC
- DO NOT REMOVE, TAMPER, ADJUST, BREAK OR ALTER IN ANY WAY THE GUARDRAIL INSTALLATION WITHOUT FIRST CONSULTING KEE SAFETY
- NO LANYARDS, LIFE LINE OR FALL ARREST PRODUCTS TO BE ATTACHED TO THE GUARDRAIL AT ANY TIME
- DO NOT ATTACH PLASTIC SHEETING OR ANYTHING THAT WOULD INCREASE THE WIND LOADING ON THE GUARDRAIL.
- IF YOU FIND THE GUARDRAIL HAS BEEN ALTERED OR TAMPERED WITH, CONTACT KEE SAFETY IMMEDIATELY

• RE-TEST ONLY TO BE CARRIED OUT BY AUTHORISED SERVICE AGENT.

SYSTEM PLAQUE - SL 111

Provides details of the system and approvals.

Material : Plastic.

Net weight : 0.085kg.

Typical Edge Protection System Layout

FIGURE 1

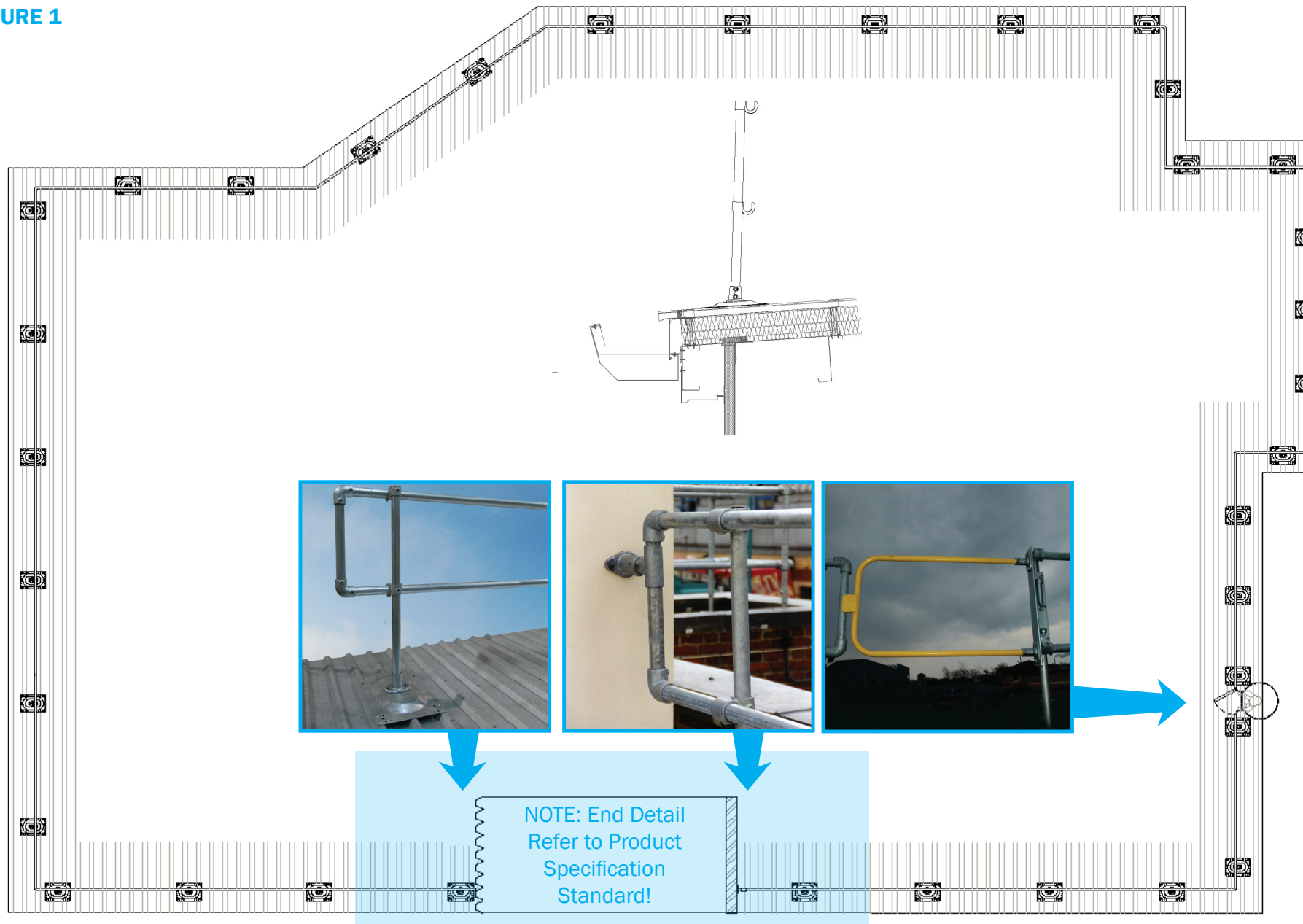

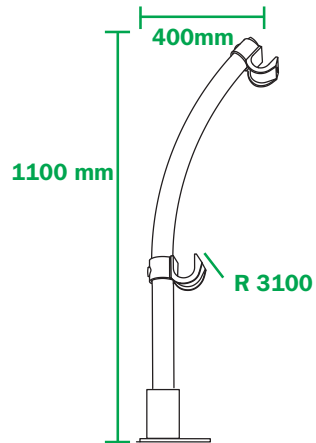

RADIUSED SUPPORT LEG

EN 14122-3 (3.2mm wall thickness) **KGTFR-U** EN 13374 (2.9mm wall thickness) **KGTF-U29**

This component allows the system to be radiused and gently curved back towards the roof slope and provides some height adjustment to the system. The Vertical Support Legs are produced in steel - 48.3mm external diameter. Material : Steel tubing to BS EN 10255 - 2.9mm Steel tubing to EN 10255 - 3.2mm. All steel components galvanised to BS EN 10240. Net weight : 7.2kg.

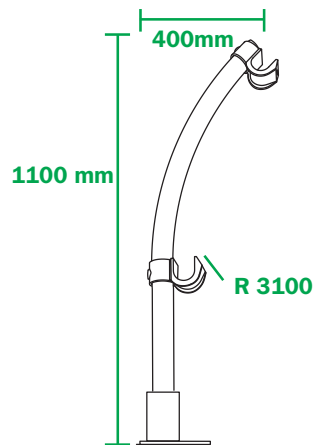

RADIUSED SUPPORT LEG

EN 14122-3 (3.2mm wall thickness) **KGTFR-U** EN 13374 (2.9mm wall thickness) **KGTF-U29**

This component allows the system to be radiused and gently curved back towards the roof slope and provides some height adjustment to the system. The Vertical Support Legs are produced in steel - 48.3mm external diameter. Material : Steel tubing to BS EN 10255 - 2.9mm Steel tubing to EN 10255 - 3.2mm. All steel components galvanised to BS EN 10240. Net weight : 7.2kg.

BASE PLATE METAL ROOFS - KGTF1

This plate provides a method of connecting the system to a metal roof structure.

Metal roof panels with minimum steel thickness of 0.7mm require 2 rivets per corner.

Includes butyl sealing strip to maintain roof's integrity (TA-SEAL 15m roll)

Fixing centres: 400, 500, 333, 310.

Composite roof panels with minimum steel thickness of 0.5mm thick require 4 rivets per corner.

Includes butyl sealing strip to maintain roof's integrity (TA-SEAL 15m roll)

Fixing centres: 333mm

Standing seam roofs

Designed to clamp on to the standing seam of a proprietary roofing sheet.

Fixed with non penetrative Z5 clamps

Fixing centres: 305, 400, 500mm

Z5 (4 per pkt)

Material : Galvanised steel to BS EN ISO 1461. Net weight : 6.6kg.

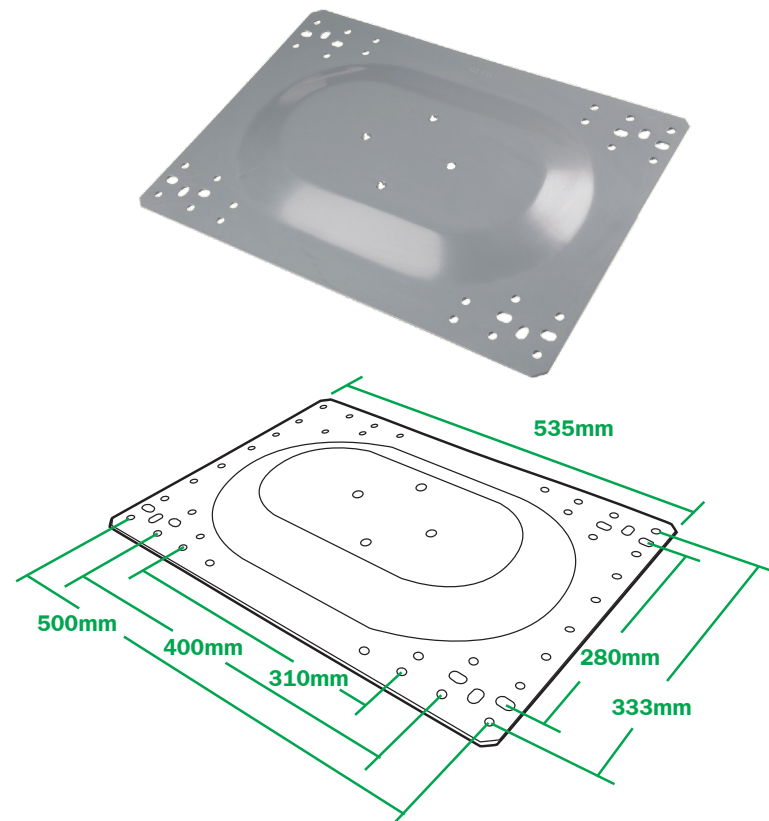

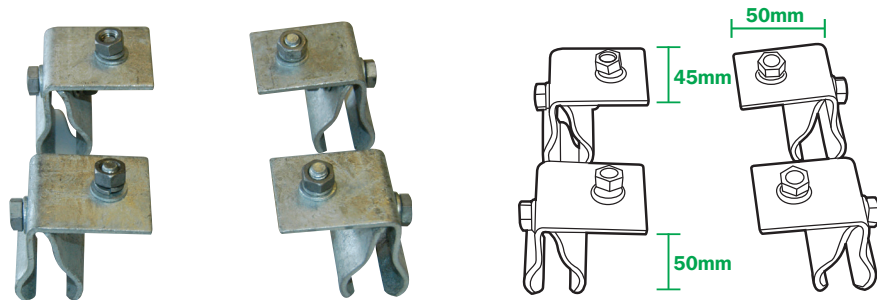

STANDING SEAM CLAMPS - WFP6

These are used in conjunction with the Base Plate Metal Roofs to connect the plate to the roof structure. Material : Galvanised steel to BS EN ISO 1461 Net weight : 1kg.



MAIN RAIL TUBE

EN 14122-3 (3.2mm wall thickness) (6.4m - 8610)(3.2m - 8610HL)(2.133m - 8610213)
EN 13374 (2.9mm wall thickness) (6.4m - 8310)(3.2m - 8310HL)(2.133m - 8310213)

Supplied in three sizes for convenience, these components provide the horizontal rails of the system. Guardrail top and intermediate rails are produced in steel - 48.3mm external diameter. Material : Steel tubing to BS EN 10255 - 2.9mm. Steel tubing to EN 10255 - 3.2mm. All steel components galvanised to BS EN 10240. Net weight : 22.9kg, 11.45kg, & 7.6kg

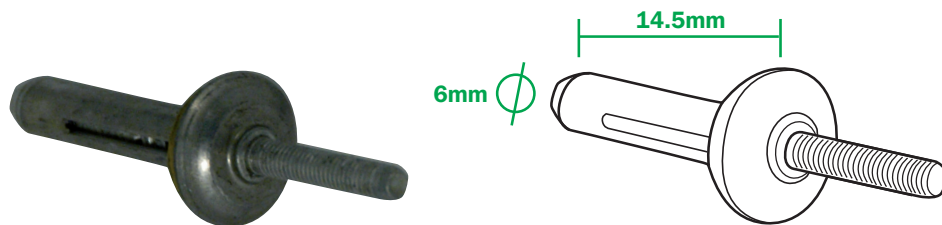

RIVETS (PKT100) - RIVETS

These are used in conjunction with the Base Plate Metal Roofs to connect the plate to the roof structure. Material : Aluminium. Net weight : 1kg per 100.



PLASTIC CAP - SL105

This component is fitted to the top of the Support Leg to prevent water ingress. Material : PVC. Net weight : 0.009kg.

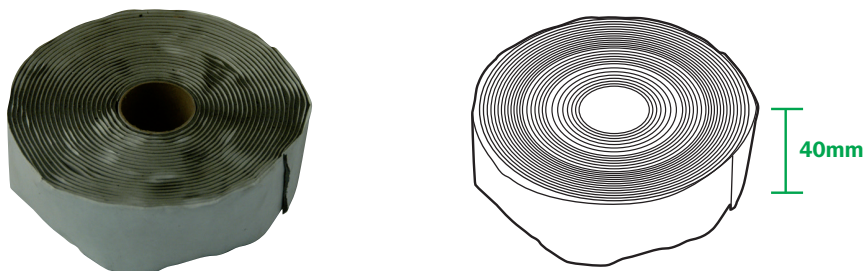

SEALING STRIP (15M ROLL) - TA-SEAL

This is used in conjunction with the Base Plate Metal Roofs to form a seal between the underside of the plate and the metal decking. Material : Butyl. Net weight : 4kg.

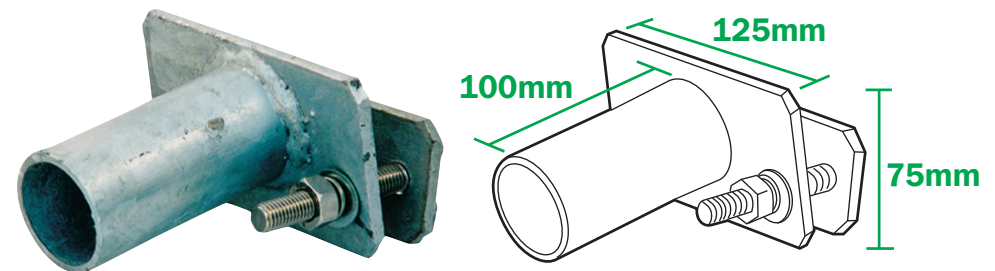

WALL/LADDER CLAMP - SL 109C

This component provides the means to terminate the system against a façade or clamp the system to a cat ladder/structure where the stringer is a maximum of 70mm wide. Material : Galvanised steel to BS EN ISO 1461. Net weight : 1.1kg.

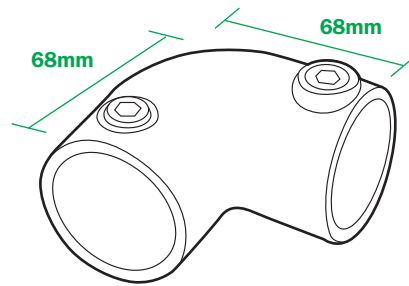

90° ELBOW - 15-8

This provides the means of dealing with corners and changes in level.
Material : Malleable cast iron to BS 1562 and galvanised to BS EN ISO 1461. Net weight : 0.76kg.

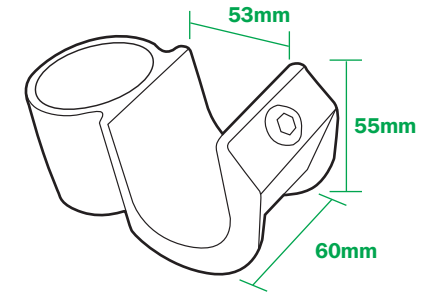

*SADDLE CLAMP - 135-8

This open cup fitting provides the method of linking the horizontal Main Rail Tubes to the Support Legs. Material : Malleable cast iron to BS 1562 and galvanised to BS EN ISO 1461. Net weight : 0.77kg.

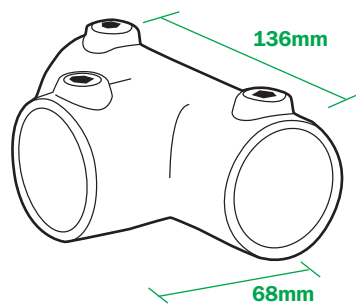

THREE SOCKET TEE CONNECTOR - 25-8

This component can be used in many different instances, for example, changes in level.
Material : Malleable cast iron to BS 1562 and galvanised to BS EN ISO 1461.
Net weight : 1.08kg.

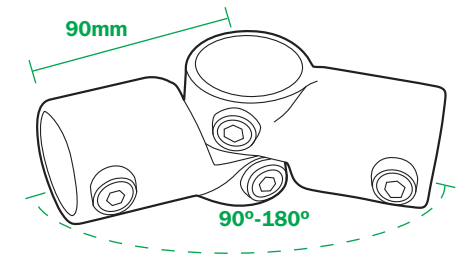

ADJUSTABLE SIDE OUTLET TEE ELBOW - 19-8

Used in pairs these components deal with angles 90°-180° and changes in level.
Material : Malleable cast iron to BS 1562 and galvanised to BS EN ISO 1461.
Net weight : 1kg.

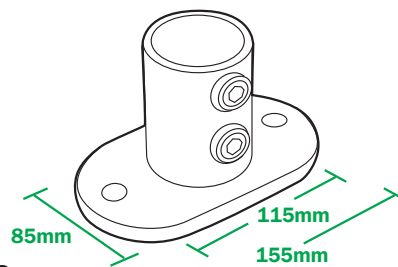

STANDARD RAILING FLANGE - 62-8

This component provides the means of connecting the Support Leg to the Base Plate. The component is also used to terminate the system against a façade.
Material : Malleable cast iron to BS 1562 and galvanised to BS EN ISO 1461.
Net weight : 1.3kg.

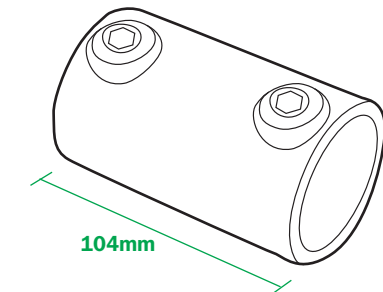

STRAIGHT COUPLING - 14-8

This component provides the method to link the horizontal Main Rail Tubes.
Material : Malleable cast iron to BS 1562 and galvanised to BS EN ISO 1461.
Net weight : 0.6kg.

* Sold as replacement parts only

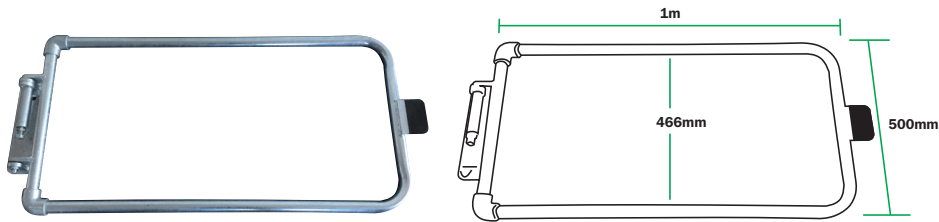

European Gate - Galvanised - SGEU500GV

Spring Loaded, self-closing safety gate. Manufactured from steel to EN 10255. 33.7mm diameter tube x 3.2mm wall thickness to meet requirements of EN 13374, EN 14122 & BS 13700. Complete with fixing pack.

Material : Galvanised steel to BS EN ISO 1461. Net weight : 11kg (24lb 4oz).

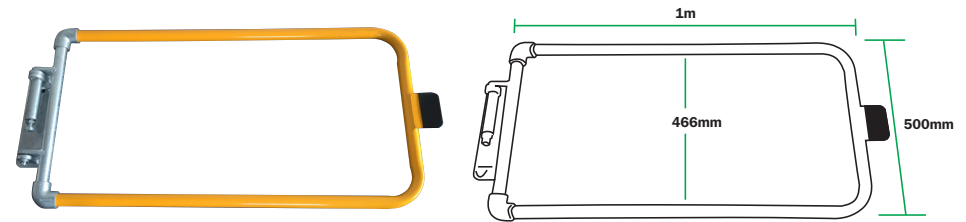

European Gate - Powder Coated - SGEU500PC

Spring Loaded, self-closing safety gate. Manufactured from steel to EN 10255 33.7mm diameter tube x 3.2mm wall thickness to meet requirements of EN 13374, EN 14122 & BS 13700.

Complete with fixing pack. Powder Coated Finish to EN 13438.

Material : Steel to EN 10255. Net weight : 11kg (24lb 4oz).



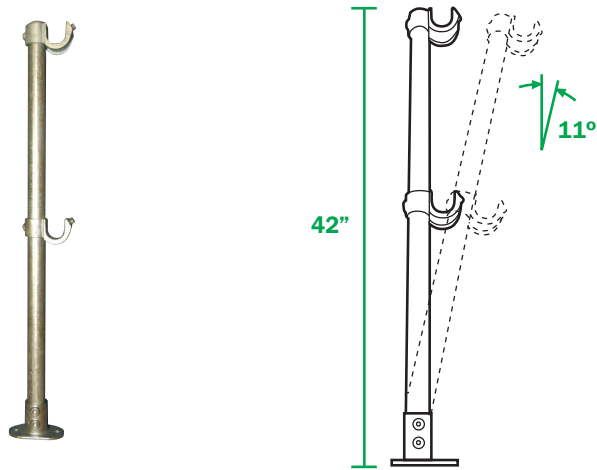

STANDARD FOLDING SUPPORT LEG - KGU135

This component allows for standard 90° installation or raked back at 11° and provides some height adjustment to the system. The Vertical Support Legs are produced in steel - 1.9" external diameter (Wall thickness 0.109"). Material : Gatorshield ASTM A-500 Carbon Steel. Zinc Spelter - ASTM B-6 High Grade Special High Grade Zinc. Net weight : 14lb

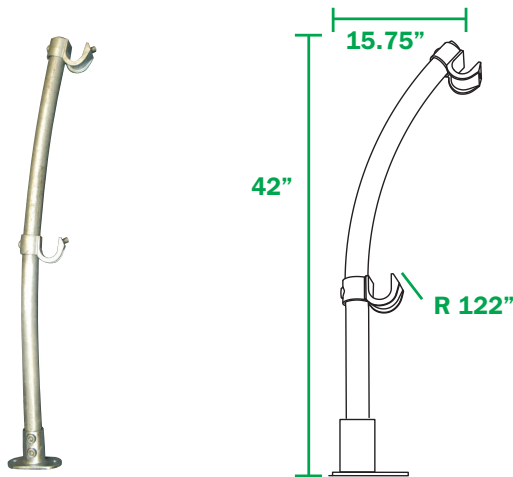

RADIUSED SUPPORT LEG - KGUR135

This component allows the system to be radiused and gently curved back towards the roof slope and provides some height adjustment to the system. The Vertical Support Legs are produced in steel - 1.9" external diameter (Wall thickness 0.109"). Material : Gatorshield ASTM A-500 Carbon Steel. Zinc Spelter - ASTM B-6 High Grade Special High Grade Zinc. Net weight : 15lb 14oz

BASE PLATE METAL ROOFS - KGTF1

This plate provides a method of connecting the system to a metal roof structure.

Metal roof panels with minimum steel thickness of 0.0275" require 2 rivets per corner. Includes butyl sealing strip to maintain roof's integrity (TA-SEAL 49' roll)
Fixing centres: 16", 18", 20.86", 24"

Composite roof panels with minimum steel thickness of 0.0197" thick require 4 rivets per corner. Includes butyl sealing strip to maintain roof's integrity (TA-SEAL 49' roll)
Fixing centres: 12" or 14.56"

Standing seam roofs

Designed to clamp on to the standing seam of a proprietary roofing sheet.
Fixed with non penetrative Z5 clamps
Fixing centres: 12", 16", 18"
Z5 (4 per pkt)

Material : Galvanised steel to ASTM A53 Net weight : 14lb 5oz

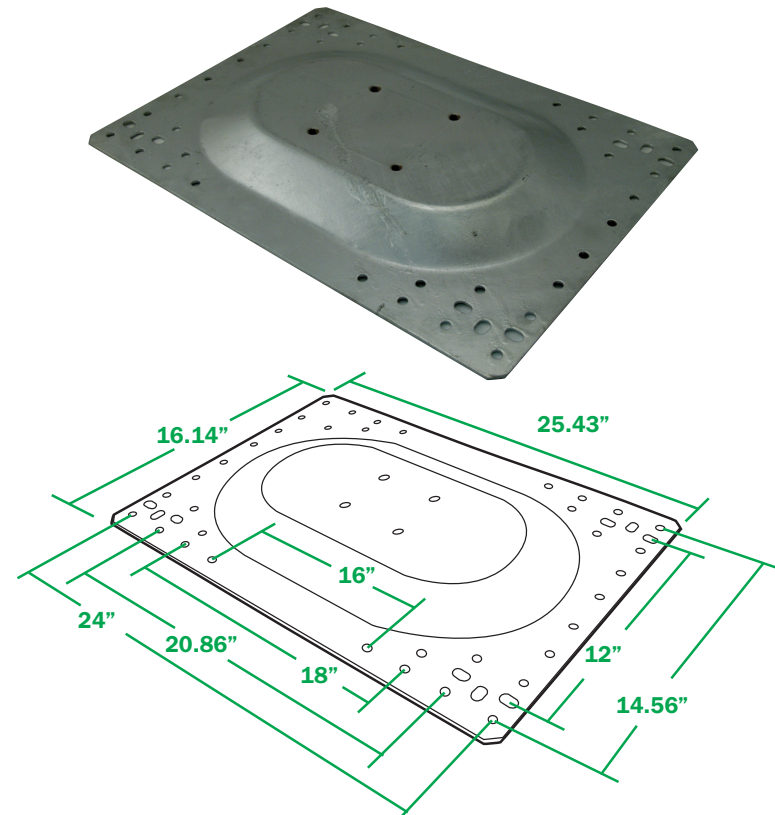

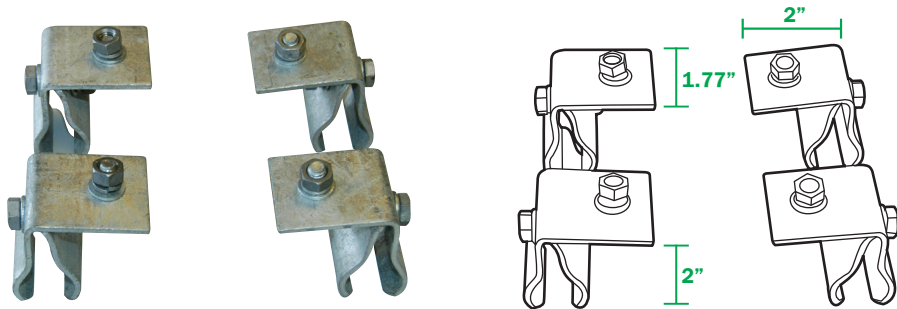

STANDING SEAM CLAMPS - WFP6

These are used in conjunction with the Base Plate Metal Roofs to connect the plate to the roof structure. Material : Galvanised steel to ASTM A53 Net weight : 2lb 3oz



MAIN RAIL TUBE (Cut to size - G150GS12GA)

Supplied in three sizes for convenience, these components provide the horizontal rails of the system. Guardrail top and intermediate rails are produced in steel - 1.9" external diameter (Wall thickness 0.109"). Material : Gatorshield ASTM A-500 Carbon Steel. Zinc Spelter - ASTM B-6 High Grade Special High Grade Zinc. Net weight : 50lb 7oz, 25lb 4oz. & 16lb 12oz.

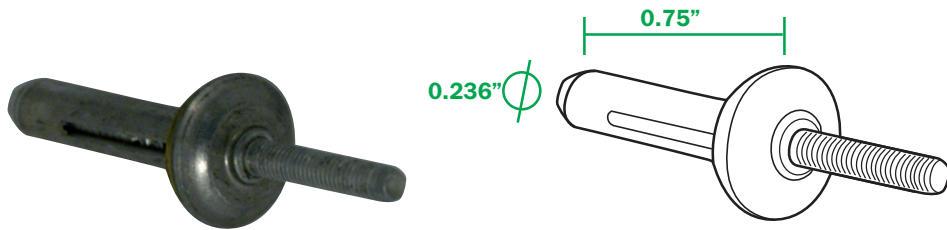

RIVETS (PKT100) - RIVETS

These are used in conjunction with the Base Plate Metal Roofs to connect the plate to the roof structure. Material : Aluminium. Net weight : 2lb 3oz per 100.

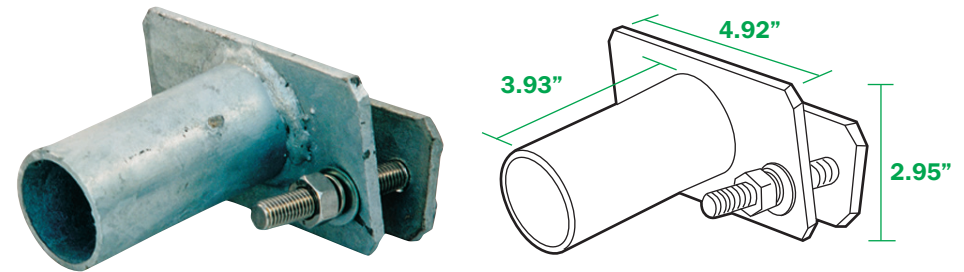

WALL/LADDER CLAMP - SL109C

This component provides the means to terminate the system against a façade or clamp the system to a cat ladder/structure where the stringer is a maximum of 2.75" wide. Material : Galvanised steel to ASTM A53. Net weight : 2lb 7oz.

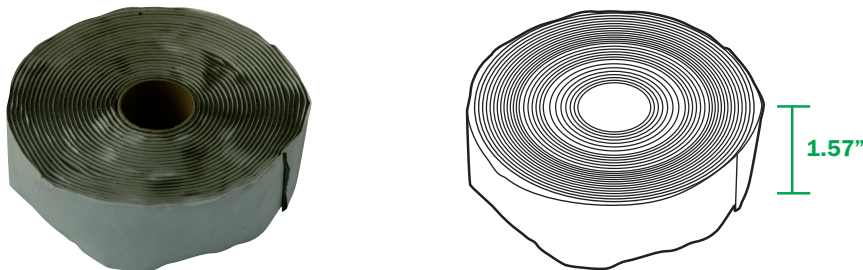

SEALING STRIP (50' ROLL) - TA-SEAL

This is used in conjunction with the Base Plate Metal Roofs to form a seal between the underside of the plate and the metal decking. Material : Butyl. Net weight : 8lb 8oz.



PLASTIC CAP - SL105

This component is fitted to the top of the Support Leg to prevent water ingress. Material : PVC. Net weight : 1/3oz.

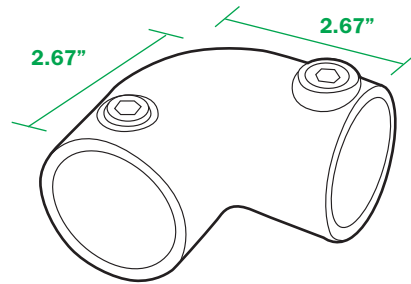

90° ELBOW - 15-8

This provides the means of dealing with corners and changes in level.
 Material : Malleable cast iron to ASTM A47-77-32510 and galvanised to ASTM 153.
 Net weight: 1lb 11oz.

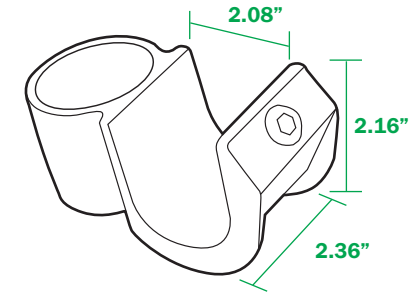

*SADDLE CLAMP - 135-8

This open cup fitting provides the method of linking the horizontal Main Rail Tubes to the Support Legs. Material : Malleable cast iron to ASTM A47-77-32510 and galvanised to ASTM 153.
 Net weight: 1lb 11oz.

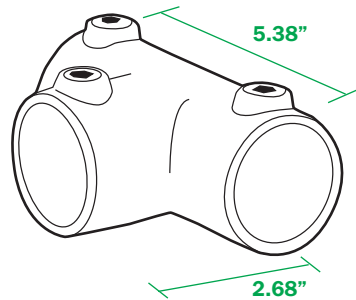

THREE SOCKET TEE CONNECTOR - 25-8

This component can be used in many different instances, for example, changes in level.
 Material : Malleable cast iron to ASTM A47-77-32510 and galvanised to ASTM 153.
 Net weight: 2lb 6oz.

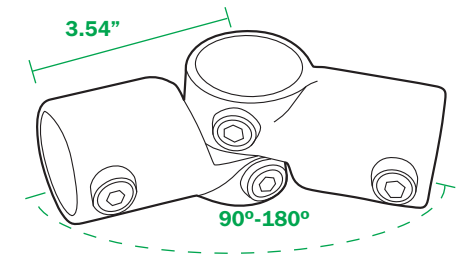

ADJUSTABLE SIDE OUTLET TEE ELBOW - 19-8

Used in pairs these components deal with angles 90°-180° and changes in level.
 Material : Malleable cast iron to ASTM A47-77-32510 and galvanised to ASTM 153.
 Net weight: 2lb 3oz.

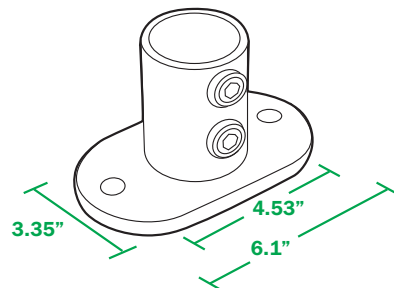

STANDARD RAILING FLANGE - 62-8

This component provides the means of connecting the Support Leg to the Base Plate. The component is also used to terminate the system against a façade.
 Material : Malleable cast iron to BS 1562 and galvanised to ASTM 153 Net weight : 2lb 7oz.

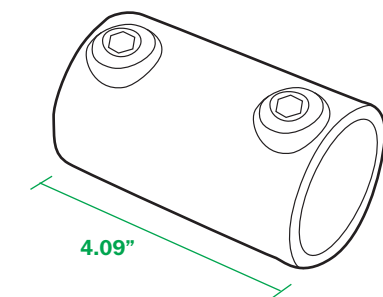

STRAIGHT COUPLING - 14-8

This component provides the method to link the horizontal Main Rail Tubes.
 Material : Malleable cast iron to ASTM A47-77-32510 and galvanised to ASTM 153.
 Net weight: 1lb 5oz.

* Sold as replacement parts only

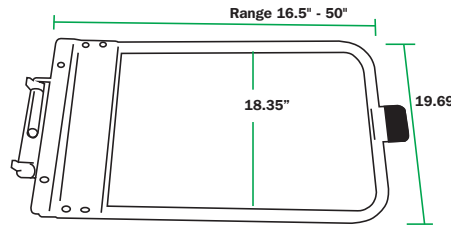

NORTH AMERICAN GATE - GALVANISED

Spring Loaded, self-closing safety gate for North America. Each model can be adjusted on site without need for cutting or welding. Complete with fixing pack.

Material : Galvanised steel to ASTM A53.

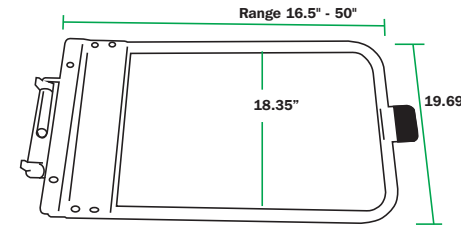

NORTH AMERICAN GATE - POWDER COATED

Spring Loaded, self-closing safety gate for North America. Each model can be adjusted on site without need for cutting or welding. Complete with fixing pack.

Powder Coated USA - AAMA 2603-2605.

Material : Galvanised steel to ASTM A53.

IMPERIAL

Single Safety Gate - Imperial

Part No.	Description	Min (in)	Mid (in)	Max (in)	Weight (lbs)
SGNA018GV	18" Gate - Galvanised	16.5	18	20	37lbs 10oz
SGNA018PC	18" Gate - Powder Coated				
SGNA021GV	21" Gate - Galvanised	19.5	21	23	38lbs 11oz
SGNA021PC	21" Gate - Powder Coated				
SGNA024GV	24" Gate - Galvanised	22.5	24	26	38lbs 13oz
SGNA024PC	24" Gate - Powder Coated				
SGNA027GV	27" Gate - Galvanised	25.5	27	29	39lbs 15oz
SGNA027PC	27" Gate - Powder Coated				
SGNA030GV	30" Gate - Galvanised	28.5	30	32	41lbs oz
SGNA030PC	30" Gate - Powder Coated				
SGNA033GV	33" Gate - Galvanised	31.5	33	35	41lbs 3oz
SGNA033PC	33" Gate - Powder Coated				
SGNA036GV	36" Gate - Galvanised	34.5	36	38	42lbs 5oz
SGNA036PC	36" Gate - Powder Coated				
SGNA040GV	40" Gate - Galvanised	38.5	40	42	43lbs 3oz
SGNA040PC	40" Gate - Powder Coated				
SGNA048GV	48" Gate - Galvanised	46.5	48	50	44lbs 15oz
SGNA048PC	48" Gate - Powder Coated				

METRIC

Single Safety Gate - Metric

Part No.	Description	Min (mm)	Mid (mm)	Max (mm)	Weight (kg)
SGNA018GV	18" Gate - Galvanised	418	457	508	16.8
SGNA018PC	18" Gate - Powder Coated				
SGNA021GV	21" Gate - Galvanised	494	533	584	17.2
SGNA021PC	21" Gate - Powder Coated				
SGNA024GV	24" Gate - Galvanised	570	610	660	17.5
SGNA024PC	24" Gate - Powder Coated				
SGNA027GV	27" Gate - Galvanised	647	686	737	17.9
SGNA027PC	27" Gate - Powder Coated				
SGNA030GV	30" Gate - Galvanised	723	762	813	18.3
SGNA030PC	30" Gate - Powder Coated				
SGNA033GV	33" Gate - Galvanised	799	838	889	18.6
SGNA033PC	33" Gate - Powder Coated				
SGNA036GV	36" Gate - Galvanised	875	914	965	19.0
SGNA036PC	36" Gate - Powder Coated				
SGNA040GV	40" Gate - Galvanised	977	1016	1067	19.4
SGNA040PC	40" Gate - Powder Coated				
SGNA048GV	48" Gate - Galvanised	1180	1219	1270	20.3
SGNA048PC	48" Gate - Powder Coated				

STANDARD SUPPORT LEG (KGTFU32) OR RADIUSED SUPPORT LEG (KGTFUR32)

These are supplied already assembled at the correct height (1100mm) (42") with the saddle clamps set at the correct position and the Base Plate Metal Roofs already attached.



KGTFU32



KGTFUR32

LAYING OUT SUPPORT LEG AND MAIN RAIL TUBES

Lay out the equipment in approximately the positions shown below. Always ensure that you and the equipment are at a safe distance from the roof edge. It is recommended that this distance is no less than 2m (6'6").

Lay out two 6.4m (21') Main Rail Tubes (8610) or (3.2m (10'6") or 2.13m (7')) side by side and in a continual line, for the whole length of the required guardrail (ensure these do not roll towards the roof edge). Then start laying out the Support Leg Units. If your start position is from a corner, start laying out the Support Legs at the following maximum centres.
 (EN 13374 & BS 13700 - 3m centres)
 (EN 14122-3 (first bay 1.75m, subsequent bays 2.5m centres))
 (USA & Canada 8' centres)
 Please refer to technical specifications.

Carry on laying out the Support Legs for the required length of guardrail.



FIGURE 1.

Fixed and Intermediate Details

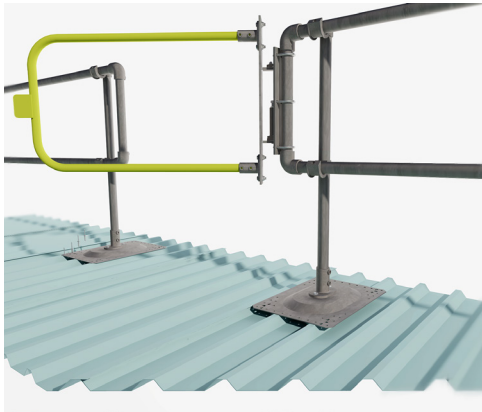

A

SELF CLOSING GATE ACCESS POINT

Components

- 1-2No. Support Legs (Position of break Dependent)
- 1No. Self closing gate (GT25P)
- 4No. 90° Elbows (15-8)
- 2No. End pieces

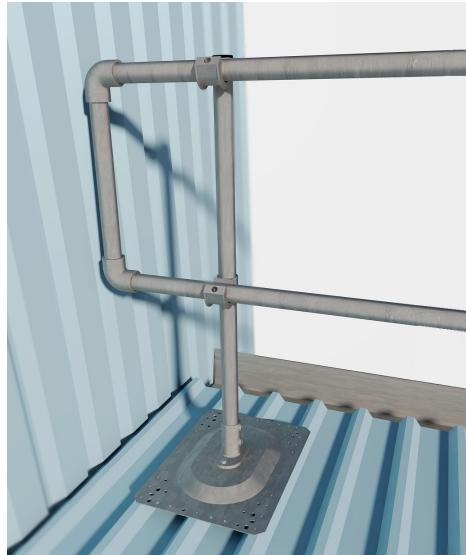

B

FREE STANDING END

Components

- 1No. Support Leg (Position of break Dependent)
- 2No. 90° Elbows (15-8)
- 1No. End piece



C

WALL CLAMP

Components

- 1No. End piece
- 1No. Three Socket Tee Connector (25-8)
- 1No. Wall/Ladder Clamp (SL109C)
- 2No. 90° Elbows (15-8)
- 2No. Wall fixings (SL110)

LAYING OUT FITTINGS

Where the two Main Rail Tubes butt together lay out 2No. Straight Couplings (14-8) in order for the Main Rail Tubes to be joined. At corners 2No. 90° Elbows will be required (15-8). (Use Adjustable Side Outlet Tee Elbows in pairs where corners/ridges are 90° - 180° (19-8)). See also Fixed and intermediate Details above for additional required components. (See figure 1)

STAGE 1

Establish the desired starting point for the first Support Post to be fitted.
 Decide the orientation of the Base Plate and fixing holes (8 minimum) that are going to be used.
 On the underside of the Base Plate Metal Roofs fix the double sided Sealing Strip along the complete length of the plate covering all the holes in the plate that are to be used for fixing the plate to the metal roof.
 Carefully remove the backing on the double sided Seal Strip and place the Base Plate Metal Roofs in the desired position.
 Firmly press down on the Base Plate Metal Roofs ensuring it's supported at all times so it's in contact with the crowns of the sheeting.
 Using a 6.7mm (2.64") drill, drill through two of the desired holes and using the rivets provided fix the plate. Ensure the remaining six holes are still aligned and finally drill and rivet the plate in place. Fix using the supplied 6.4mm x 14.5mm (0.236" x 0.57") rivets provided.

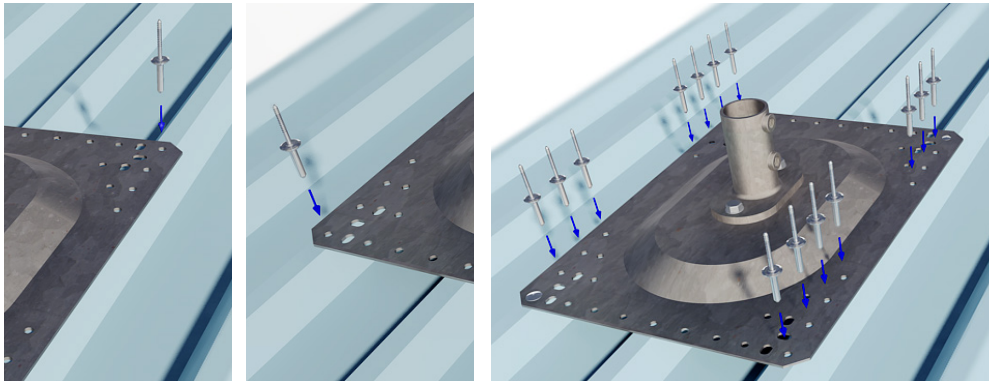

Repeat the above process for the next Base Plate Metal Roofs (Max centres - refer to technical specification for recommended centres) ensuring it's aligned with the first Base Plate Metal Roofs. This is essential to maintain a straight guardrail installation.

STAGE 2

Insert the Support Legs with the open cup Saddle Clamp (135-8) facing inwards and tighten the grub screws on the Standard Railing Flange (62-8)
 Place a Main Rail Tube (8610) into the bottom Saddle Clamp (135-8) of each of the Standing Legs.
 Position the tube so there is at least 60mm (2.5") protruding from the Saddle Clamp (135-8), and tighten the grub screw.
 These are located on the front of the Saddle Clamp (135-8).
 Place the second Main Rail Tube (8610) into the top Saddle Clamp (135-8), positioning the tube as before, leaving at least 60mm (2.5") of the tube protruding from the Saddle Clamp (135-8), and tighten the grub screw of the Saddle Clamp (135-8).

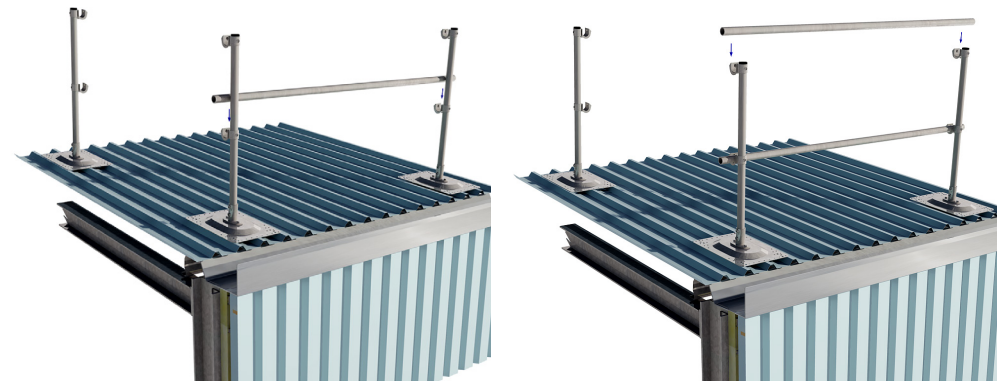

STAGE 3

Working away from the corner slide a Straight Coupling (14-8) on to the top and intermediate Main Rail Tubes. Ensure the Straight Couplings (14-8) are off set as shown. As far as possible only use one Straight Coupling (14-8) per bay.

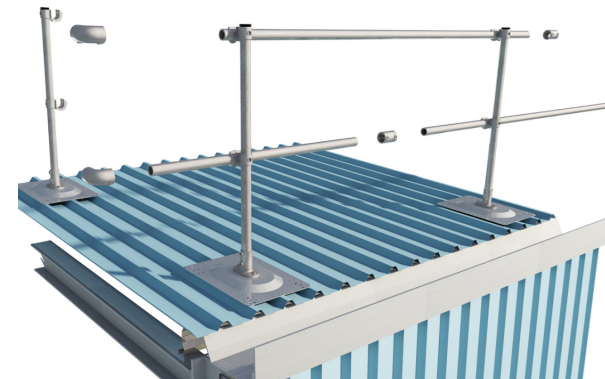

STAGE 4

Repeat Stages 2-3 and continue with this method of fitting the Main Rail Tube (8610) and Support Legs together for this run of guardrail, remembering to align the Base Plate Metal roofs, ensuring it's aligned with the first Base Plate Metal Roofs. This is essential to maintain a straight guardrail installation. Adjust, line and level guardrail. Now repeat (STAGE 1-4) above for the remaining runs. Position the clamp so the grub screw are facing outwards and tighten the grub screw at the connected end.

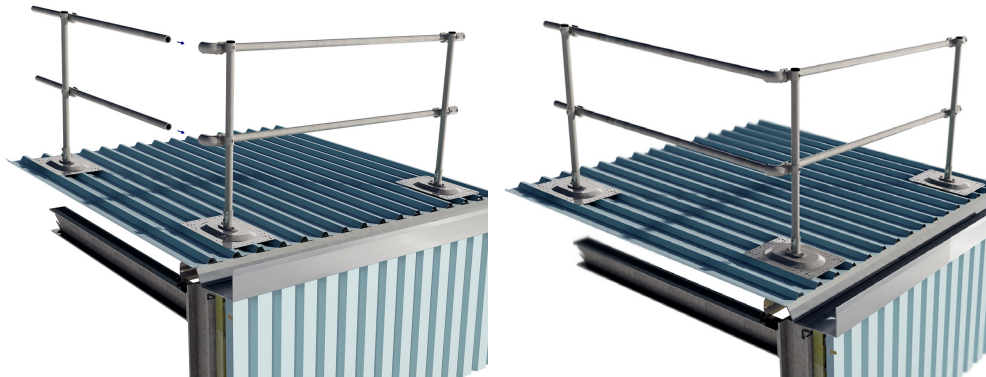

(EN 13374 & BS 13700 - 3m centres)
 (EN 14122-3 (first bay 1.75m, subsequent bays 2.5m centres))
 (USA & Canada 8' centres)

Please refer to technical specifications.

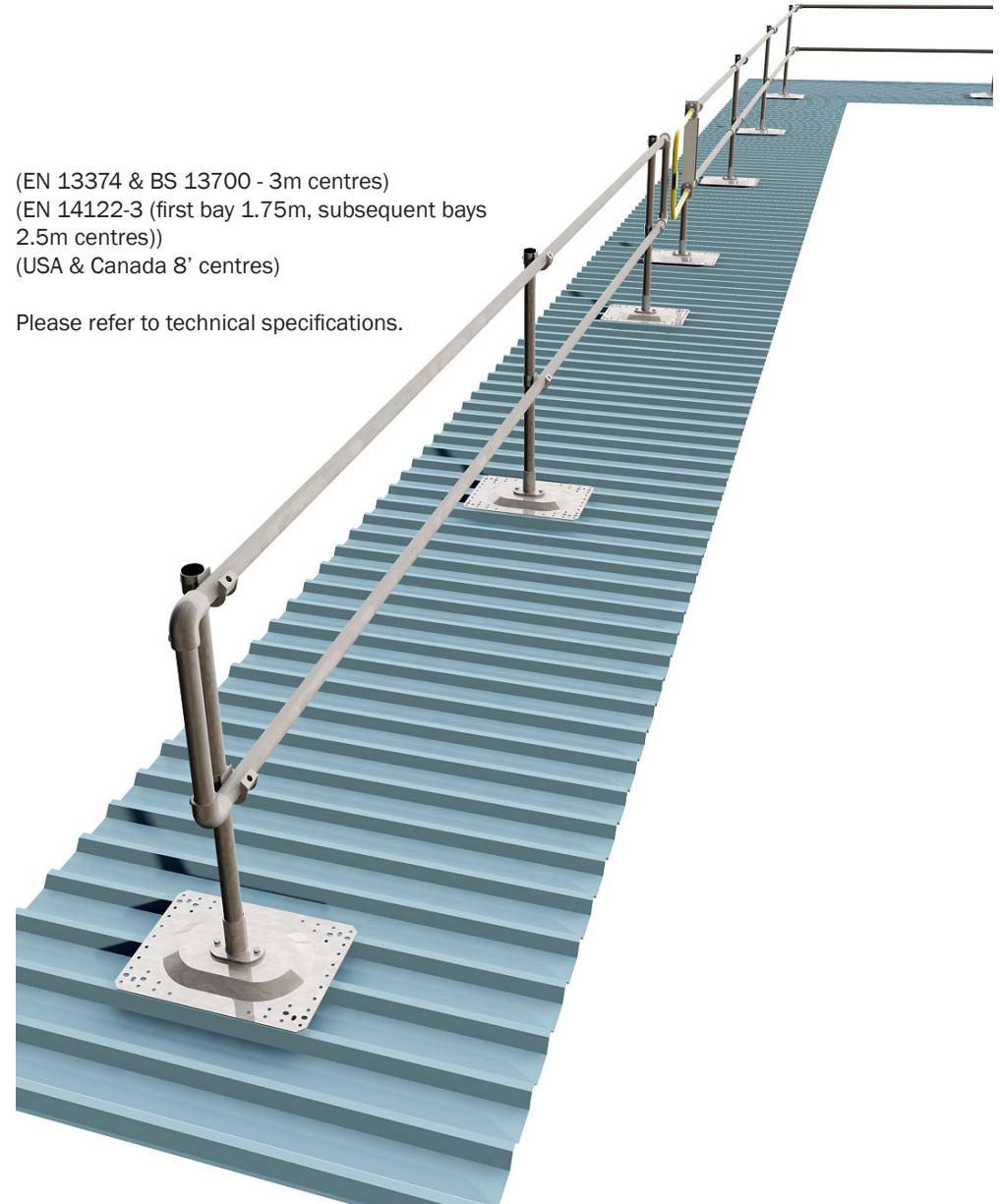

STAGE 5

Determine the end detail and finish the guardrail accordingly (See Fixed and Intermediate Details).

WARNING

Under no circumstances should any person be anchored to the system for fall arrest purposes. Further, components such as timber infill, advertising boards, polyethylene sheets must not be fixed to the system.





- Periodic inspections by a competent person are recommended by the manufacturer. In UK/Europe these are required under Regulation 5 of the Workplace (Health, Safety & Welfare) Regulations, the Work at Height Regulations and BS EN 365 & BS 13700. The frequency will depend upon the environment, location and usage but should be at least every 12 months.
- Walk and visually inspect the complete installed system in relation to the general client's needs. Establish if any modifications and/or additional products are required to reflect any refurbishment requirements or additional plant & equipment which have been installed and require access.
- Check installation configuration is complete as per the original installation drawing/plan.
- Ensure the system has not been modified or tampered with by unauthorised persons.
- Check all rivets connecting Base Plate Metal Roofs.
- Check all grub screws are in place, greased and sufficiently torque.
- Check that the general height and level of the system including the leg centres.
(This only tends to be an issue if the system has been tampered with between inspections).
- Any galvanised components showing signs of corrosion should be wire brushed thoroughly and galvanised spray/paint applied as appropriate.
If rusted significantly, take digital photographs and include these in the inspection report.
- Where toe-boards are fitted check the brackets that support the toe-board are in place, greased and sufficiently torqued.
- Where applicable, check fixings to walls/structures including cat ladder clamps are in place, greased and sufficiently torqued.
- Check system plaque position & mark up to reflect date of the next required inspection. Establish if additional plaques are required due to any refurbishment works.



Kee Safety LLC
Dubai Investment Park
Near Green Community
PO Box 18448
Dubai, United Arab Emirates

Tel.: +971 4 885 9066

Email: uaesales@keesafety.com

Website: www.keesafety.ae