



SAFETY AT THE HIGHEST LEVEL

# KeeGuard Operation & Maintenance Manual







## SAFETY GUARDRAIL SYSTEMS

The Company's guardrail system KEEGUARD has been designed specifically to provide permanent edge protection for areas where regular access for maintenance and inspection is required.

## UNIQUE SYSTEMS

Each system's unique design provides permanent edge protection without the need to mechanically fix the system through the roofing membrane or building's structure. Their simple cantilever principle provides unrivalled strength, stability and safety and overcomes the problems associated with traditional systems such as having to drill and puncture the roof membrane which can lead to potential penetrative water damage and noise disturbance during installation. Similarly, high levels of insulation included within warm deck and inverted flat roof designs often mean it is virtually impossible to fix through, as with traditional systems, without causing cold bridging. This may then cause interstitial condensation to form within the flat roof construction, causing the roof to deteriorate and eventually require replacement. When it is not appropriate to use counter balanced systems, such as modern industrial cladded pitched roofs, KeeGuard Topfix may be an alternative to traditionally fixed systems.



## DURABLE SYSTEMS

The Company's guardrail connections are supplied with a galvanised finish carried out to BS EN ISO 1461 and ASTM A53: Hot Dip Galvanised Coatings Specification and Testing Methods, giving an average coating of between 65-85 microns. All products are also available in aluminium. All cast clamps have Threadcoat applied to all tapped holes. All grub screws are carbon steel and have Keekoat protection applied to ensure minimal maintenance.

## COMPONENT BASED SYSTEMS

All systems consist of galvanised/aluminium tubing joined together using the KEE KLAMP method of connection. KEEGUARD, raked, radiused and folding systems' base feet connect to the 100% recycled PVC counter weight, giving the system its strength & stability.



## VERSATILE SYSTEMS

All systems have been specially designed to fit any shape and size of flat and pitched roofs, even circular designs. The systems can also cope with changes in levels, roof falls and difficult details such as ductwork passing over the roof edge and cable trays/plant mounted at the roof edge. The flexibility of the counter weight & KEE KLAMP design allows the systems to be used on plant congested or complex detailed roofs. The product range has been extended to suit specific requirements and includes the standard design with vertical legs, raked and radiused systems, as well as a folding version for areas where a more discreet form of protection is required. KeeGuard Topfix has also been added to the range to provide collective protection solutions for industrial cladded pitched roofs.



## MEMBRANE PROTECTION SYSTEMS

Each system is installed with rubber matting bonded to the underside of metal components which come into contact with the roof membrane. In some cases the counter weight and base foot have sacrificial pads placed between the edge protection components and the roof membrane. This protects the roof membrane from damage via heat transfer or direct contact with components. On warm deck roof construction specifications pedestrian tiles are recommended to be placed where base feet and counter weights are in contact with the roof membrane. Where KeeGuard Topfix is installed a butyl strip is used where the Base Plates are fixed, via rivets, to the roof cladding.

## TESTING & CERTIFICATION

Tested in accordance with:-  
 EN 13374 Class A.  
 BS 13700, Permanent counterweighted guardrail systems – Specification  
 EN ISO 14122 Part 3.  
 NF E85-003  
 EN 1991-1-4  
 BS 6399 : Part 2 Code of Practice for Wind Load.

## WIND CALCULATED

Wind loading is the most likely regular and demanding force a free standing roof guardrail will encounter during its lifetime. The Company has developed a computerised programme to calculate the design to ensure compliance with the relevant wind loadings relating to the topography, height and location of the project throughout the World.

## OFFICIAL DOCUMENTATION

All Systems comply with the following:-  
 Work at Height Regulations.  
 HSG 33 “Health & Safety in Roof work”  
 HSE Construction Sheet No. 21 “Working on flat roofs protection against falls.”  
 European Union Directives together with requirements of CDM Regulations.

## AESTHETICS

The smooth lines of the standard galvanised/aluminium finish can be further enhanced by the application of powder coating to BS 6497 Specification for Powder Organic Coatings, EU Codes with bespoke colour produced to special order. Counter weights are available in black or other colours at an additional cost. Where a more discreet form of protection is required, raked and radiused systems, as well as a folding version are welcomed by Planning Officers due to their improved aesthetics.

## SYSTEMS DISTRIBUTORS

All systems are available as a supply and installation service or component supply only. Products are available from The Company directly or one of its licensed distributors.

## INDUSTRIAL CLADDED ROOFS

The Company has developed a new collective roof edge protection system, KeeGuard Topfix specifically for metal profile and standing seam roofs up to 45°. Pitched cladded roofs have traditionally been protected using personal fall protection systems which are lower in the hierarchy of controls.

## PRODUCT SPECIFICATION - EN 13374 & BS 13700

**FEATURES:-** Standard Vertical, Raked, Radiused System  
Recycled PVC Counter Weight System

### GENERAL

KeeGuard® systems do not require physical fixing into the roof's structure/membrane. The complete system's design, manufacture, testing and installation has been externally assessed and tested to EN 13374 & BS 13700

### MATERIALS

Steel tubing to BS EN 10255 - 2.9mm.

Steel tubing to EN 10255 – 3.2mm.

All steel components galvanised to BS EN 10240.

Guardrail top and intermediate rails are produced in steel - 48.3mm external diameter. (Wall thickness 2.9mm).

The vertical support legs are produced in steel - 48.3mm external diameter. (Wall thickness 2.9mm) Cantilever tubes are produced in steel – 42.4mm external diameter. (Wall thickness 3.2mm) All cast clamps have Threadcoat applied to all tapped holes. All grub screws are carbon steel and have Keekoat protection applied to ensure minimal maintenance. All cast clamps used to join the guardrail are galvanised malleable cast iron produced to BS EN 1562 : founding malleable cast iron. All metal components in contact with the roof membrane are covered with 3mm fluted rubber. Counter weights are manufactured from recycled PVC.

Where tubing is cut on site zinc rich paint is applied to the cut end of the tube.

### LAYOUT

Height of guardrail is set at 1100mm. All vertical supports are set at maximum 3m centres depending on the system.

Recycled PVC counter weights are attached to every vertical leg set at no more than 3m centres. At corner Support Legs there is no need for a PVC Counter Weight to be connected. All stop ends are appropriately counter weighted according to roof pitch and membrane (see table) or supported by way of a wall/ladder clamp.

### TESTING

All systems have been tested to EN 13374: Temporary Edge Protection Systems – Product Specification Test Methods and have been awarded a Class A Pass. All systems have been tested to BS 13700: Permanent counterweighted guardrail systems – Specification and been awarded a pass.

### WIND LOADING

All installations are wind speed calculated to BS 6399 : Part 2 : Code of Practice for Wind Loads. Eurocode 1: Actions on structures - Part 1-4: General actions - Wind loads.



EN 13374 & BS 13700						
Roof Type	MAX Pitch	Tube Size	Tube Thickness	End Counter Balance No.'s	MAX Bay Centres	Intermediate Counter Balance No.'s
<b>Mineral Grade Felt</b>						
Restrained	10°	8	2.9mm	CB2	3m	1
UnRestrained	10°	8	2.9mm	CB3	3m	1
<b>PVC Membrane</b>						
Restrained	10°	8	2.9mm	CB2	3m	1
UnRestrained	10°	8	2.9mm	CB7	3m	1
UnRestrained	5°	8	2.9mm	CB5	3m	1

## PRODUCT SPECIFICATION – EN 14122-3 & NF E85-003

**FEATURES:-** Standard Vertical, Raked, Radiused System.  
Recycled PVC Counter Weight System

### GENERAL

KeeGuard® systems do not require physical fixing into the roof's structure/membrane. The complete system's design, manufacture, testing and installation has been externally assessed and tested to EN 14122-3 & NF E85-003

### MATERIALS

Steel tubing to EN 10255 (Wall thickness 3.2mm).  
All steel components galvanised to BS EN 10240.  
Guardrail top and intermediate rails are produced in steel - 48.3mm external diameter (Wall thickness 3.2mm).  
The vertical support legs are produced in steel - 48.3mm external diameter (Wall thickness 4.0mm).  
Cantilever tubes are produced in steel - 42.4mm external diameter (Wall thickness 3.2mm).  
All cast clamps have Threadcoat applied to all tapped holes. All grub screws are carbon steel and have Keekoat protection applied to ensure minimal maintenance.  
All cast clamps used to join the guardrail are galvanised malleable cast iron produced to BS EN 1562 : founding malleable cast iron.  
All metal components in contact with the roof membrane are covered with 3mm rubber.  
Counter weights are manufactured from recycled PVC.  
Where tubing is cut on site zinc rich paint is applied to the cut end of the tube.

### LAYOUT

Height of guardrail is set at 1100mm. All vertical supports are set at maximum 2.4m centres depending on the system.  
First bay of all installations vertical supports are set at maximum 2.0m centres.  
Recycled PVC counter weights are attached to every vertical leg set at no more than 2.4m centres. At corner Support Legs there is no need for a PVC Counter Weight to be connected.  
All stop ends are appropriately counter weighted according to roof pitch and membrane (see table) or supported by way of a wall/ladder clamp.

### TESTING

All systems have been tested to EN 14122-3 & NF E85-003.

### WIND LOADING

All installations are wind speed calculated to Eurocode 1: Actions on structures - Part 1-4: General actions - Wind loads.



## EN 14122-3 & NF E85-003

Roof Type	MAX Pitch	Tube Size	Tube Thickness	End Counter	MAX End Bay Length	Intermediate Counter Balance No.'s	MAX Subsequent Bay Lengths
Mineral Grade Felt							
UnRestrained	3°	8	3.2mm	CB4	2m	1	2.4m

**CANTILEVERED ROOF EDGE PROTECTION**  
SEPARATING PEOPLE FROM HAZARDS

- THIS GUARDRAIL IS TESTED TO EN 13374EN 14122-3
- THIS GUARDRAIL IS TESTED TO BS 13700: PERMANENT COUNTERWEIGHTED GUARDRAIL SYSTEMS- SPECIFICATION
- DO NOT REMOVE, TAMPER, ADJUST, REMOVE OR ALTER IN ANY WAY THE GUARDRAIL INSTALLATION WITHOUT FIRST CONSULTING KEE SAFETY.
- NO LANYARD LIFE LINE OR FALL ARREST PRODUCTS TO BE ATTACHED TO THE GUARDRAIL AT ANY TIME.
- DO NOT ATTACH PLASTIC SHEETING OR ANYTHING THAT WOULD INCREASE THE WIND LOADING ON THE GUARDRAIL.
- IF YOU FIND THE GUARDRAIL HAS BEEN ALTERED OR TAMPERED WITH, CONTACT KEE SAFETY IMMEDIATELY.

**RE-TEST ONLY TO BE CARRIED OUT BY AUTHORISED SERVICE AGENT.**

HEAD OFFICE  
Kee Safety Limited  
Cradley Business Park  
Overend Road  
Cradley Heath  
West Midlands B64 7DW

(t) +44 (0) 1384 632 188  
(f) +44 (0) 1384 632 192  
(e) info@keesafety.co.uk  
(w) www.keesafety.co.uk

### SYSTEM PLAQUE - SL 111

Provides details of the system and approvals. Material : Plastic. Net weight : 0.085kg.

## PRODUCT SPECIFICATION – USA & Canada

**FEATURES:-** Standard Vertical, Raked, Radiused System.  
Recycled PVC Counter Weight System.

### GENERAL

KeeGuard® systems do not require physical fixing into the roof's structure/membrane. The complete system's design, manufacture, testing and installation has been externally assessed.

### TESTING

All systems have been tested to:-  
 OSHA Reg 29 CFR 1910.23 (E) (1); (E) (3) (IV).  
 OSHA Reg 29 CFR 1926.501 (b) (1); (b) (2) (ii)  
 OSHA Reg 29 CFR 1926.502 (B) (1) - (B) (14)  
 Canadian National Building Code 4.1.10.1(1)(e), 4.1.10.1(2), 4.1.10.1(4)  
 Ontario Building Code Section 4.1.10.1(1)(b), 4.1.10.1(2), 4.1.10.1(4)  
 California Building Code 1710A.3.1 (24 hour 400lbs point load)  
 California Code of Regs Title 8 Sections 3209 & 3294

### MATERIALS

Gatorshield Tubing  
 Base Metal: ASTM A-500 Carbon Steel.  
 Zinc Spelter - ASTM B-6 High Grade Special High Grade Zinc.  
 Chemical Composition - ASTM A-500.  
 Material Testing - ASTM-500 and ASTM E-8.  
 Guardrail top and intermediate rails are produced in steel - 1.9" external diameter (Wall thickness 0.109").  
 The vertical support legs are produced in steel - 1.9" external diameter (Wall thickness 0.109").  
 Cantilever tubes are produced in steel - 1.66" external diameter (Wall thickness 0.109").  
 All cast clamps have Threadcoat applied to all tapped holes. All grub screws are carbon steel and have Keekoat protection applied to ensure minimal maintenance.  
 All cast clamps used to join the guardrail are galvanised malleable cast iron produced to ASTM A47-77-32510.  
 All metal components in contact with the roof membrane are covered with 0.118" rubber.  
 Counter weights are manufactured from recycled PVC.  
 Where tubing is cut on site zinc rich paint is applied to the cut end of the tube.

### LAYOUT

Height of guardrail is set at 42". All vertical supports are set at maximum 8' centres depending on the system.  
 Recycled PVC counter weights are attached to every vertical leg set at no more than 8' centres. At corner Support Legs there is no need for a PVC Counter Weight to be connected.  
 All stop ends are appropriately counter weighted according to roof pitch and membrane (see table) or supported by way of a wall/ladder clamp.

### WIND LOADING

All installations are wind speed calculated to ASCE7 - The American Society of Civil Engineers design standard: "Minimum Design Loads for Buildings and Other Structures"



USA & CANADA								
Roof Type	Max Pitch	Tube Size	Tube Thickness (inches)	End Counter Balance No's	End Bay Length (feet)	2nd Vertical Leg Counter Balance No's	Subsequent Counter Balance No's	Susequent Bay Length (feet)
<b>Mineral Grade Felt</b>								
Unrestrained	5°	8	0.109"	CB7	8'	CB1	CB1	8'
Unrestrained	5°	8	0.109"	CB4	3' 3"	CB3	CB1	8'
Unrestrained	10°	8	0.109"	CB8	6' 6"	CB1	CB1	6' 6"
<b>TPO - Single Ply Membrane</b>								
Unrestrained	5°	8	0.109"	CB7	8'	CB1	CB1	8'
Unrestrained	10°	8	0.109"	CB8	6' 6"	CB1	CB1	6' 6"
<b>EPDM - Single Ply Membrane</b>								
Unrestrained	5°	8	0.109"	CB7	8'	CB1	CB1	8'
Unrestrained	10°	8	0.109"	CB8	6' 6"	CB1	CB1	6' 6"

CAL OSHA								
Roof Type	Max Pitch	Tube Size	Tube Thickness (inches)	End Counter Balance No's	End Bay Length (feet)	2nd Vertical Leg Counter Balance No's	Subsequent Counter Balance No's	Susequent Bay Length (feet)
<b>Mineral Grade Felt</b>								
Unrestrained	5°	8	0.109"	CB8	3'3"	CB6	CB1	6'6"

# Typical Edge Protection System Layout

FIGURE 1

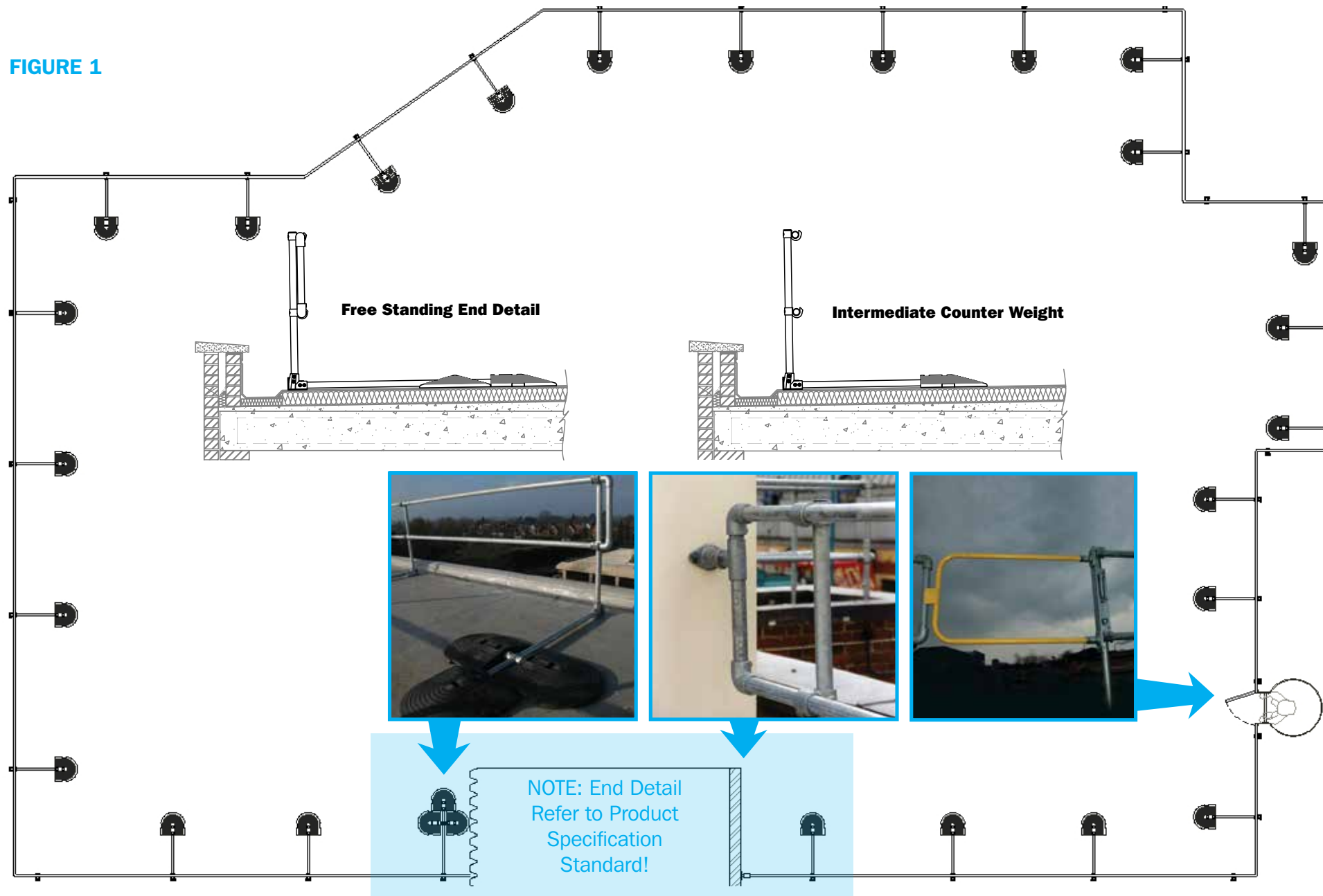



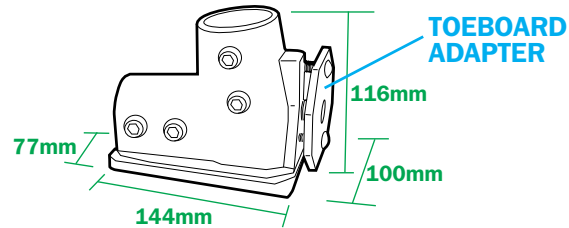

**\*BASE FOOT - 11308-7510 (T1308-7510-TOE-BOARD-OPTION)**

This unique component provides support to the system and allows the system to be set at 90° or raked back at 11°. The Base Foot connects the Cantilever Tubes and Counter Weights. The base is bonded with fluted rubber matting for membrane protection.

Material : Malleable cast iron to BS 1562 and galvanised to BS EN ISO 1461. Net weight : 1.9kg.  
**REPLACEMENT RUBBER PAD - K1351-4080**

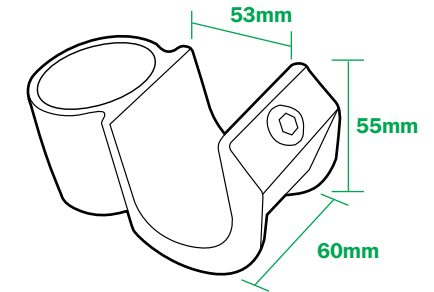

**\*SADDLE CLAMP - 135-8**

This open cup fitting provides the method of linking the horizontal Main Rail Tubes to the Support Legs. Material : Malleable cast iron to BS 1562 and galvanised to BS EN ISO 1461. Net weight : 0.77kg.

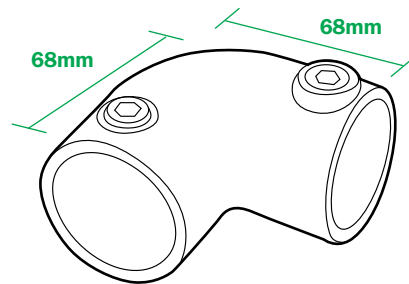

**90° ELBOW - 15-8**

This provides the means of dealing with corners and changes in level. Material : Malleable cast iron to BS 1562 and galvanised to BS EN ISO 1461. Net weight : 0.76kg.

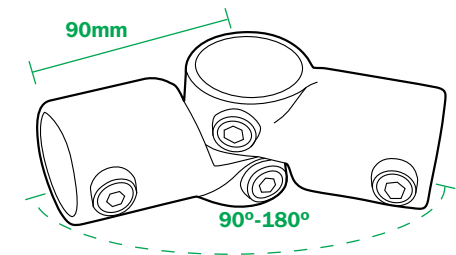

**ADJUSTABLE SIDE OUTLET TEE ELBOW - 19-8**

Used in pairs these components deal with angles 90°-180° and changes in level. Material : Malleable cast iron to BS 1562 and galvanised to BS EN ISO 1461. Net weight : 1kg.

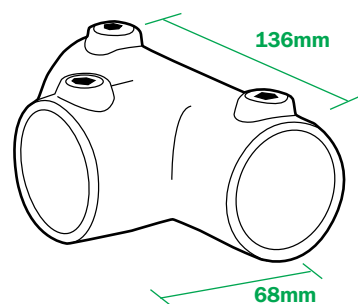

**THREE SOCKET TEE CONNECTOR - 25-8**

This component can be used in many different instances, for example, changes in level. Material : Malleable cast iron to BS 1562 and galvanised to BS EN ISO 1461. Net weight : 1.08kg.

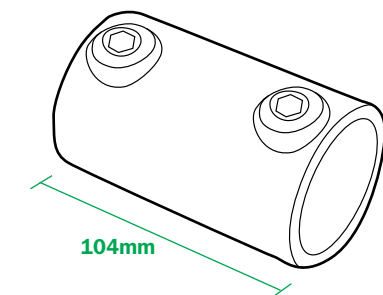

**STRAIGHT COUPLING - 14-8**

This component provides the method to link the horizontal Main Rail Tubes. Material : Malleable cast iron to BS 1562 and galvanised to BS EN ISO 1461. Net weight : 0.6kg.

**\* Sold as replacement parts only**

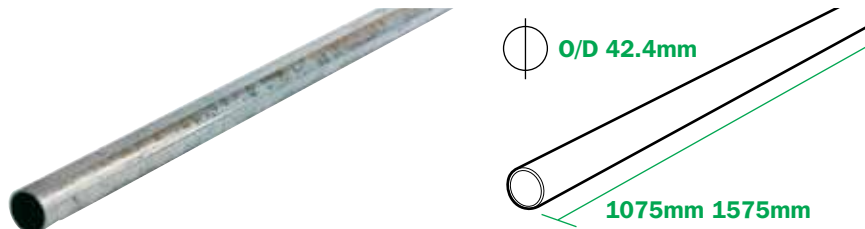

### CANTILEVER TUBE - (1075mm - CBT1) (1575mm - CBT2)

This component provides the link between the Counter Weight and Base Foot.  
 Material : Steel tubing to EN 10255 - 3.2mm. All steel components galvanised to BS EN 10240.  
 Cantilever tubes are produced in steel – 42.4mm external diameter. (Wall thickness 3.2mm) First/ last Cantilever tube length 1575mm Net weight : 4.48kg. Intermediate cantilever tube length 1075mm Net weight : 3.26kg.

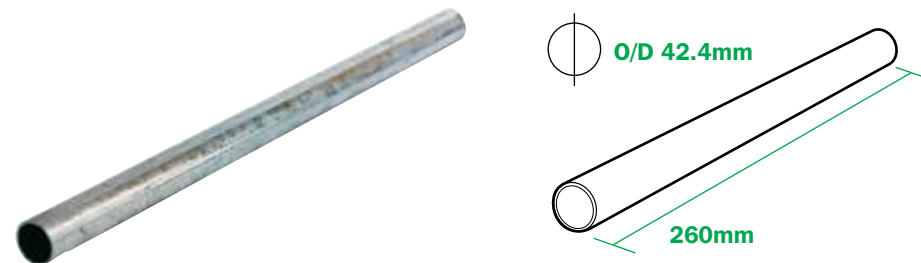

### SMALL CANTILEVER TUBE/COUNTER WEIGHT LINK - CBT3

Used in pairs at the end details these components provide the link between the Counter Weights and the Cantilever Tube via the Two Socket Cross fitting. Material : Steel tubing to EN 10255 - 3.2mm. All steel components galvanised to BS EN 10240. Tubes are produced in steel – 42.4mm external diameter. (Wall thickness 3.2mm) Net weight : 0.78kg.



### MAIN RAIL TUBE

Supplied in three sizes for convenience, these components provide the horizontal rails of the system. Guardrail top and intermediate rails are produced in steel - 48.3mm external diameter. Material : Steel tubing to BS EN 10255 - 2.9mm. Steel tubing to EN 10255 - 3.2mm. All steel components galvanised to BS EN 10240. Net weight : 22.9kg, 11.45kg, & 7.6kg

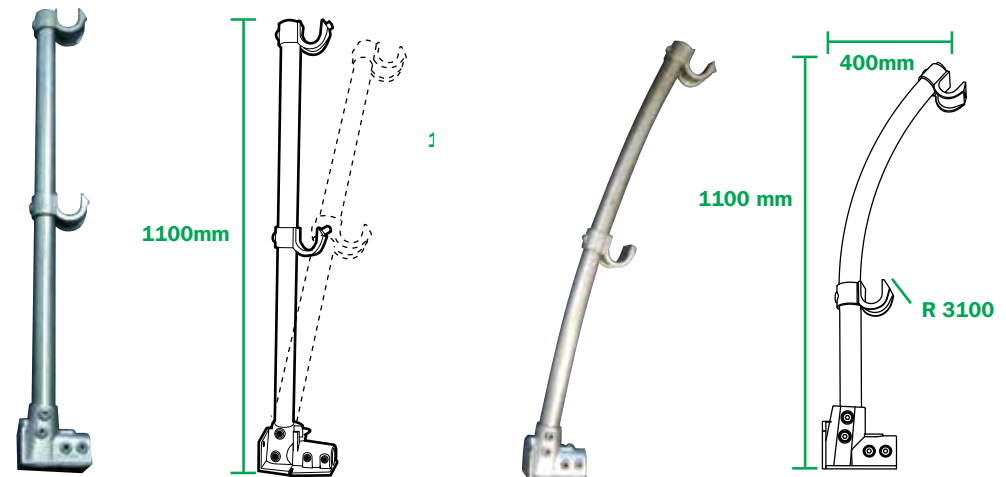

### STANDARD, RAKED, RADIUSED & BENT SUPPORT LEG

These assemblies allow the guardrail to be installed in different orientations:- standard 90°, raked back at 11°, radiused and bent.  
 The support leg also allows for height adjustment to the system. The vertical support legs are produced in steel - 48.3mm external diameter. Material : Steel tubing to BS EN 10255 - 2.9mm. Steel tubing to EN 10255 – 3.2mm. All steel components galvanised to BS EN 10240.

DESCRIPTION	EN 13374 CLASS A & BS13700		EN 14122 Part C	
	Wall Thickness 2.9mm		Wall Thickness 3.2mm	
	Part Code	Weight kg	Part Code	Weight kg
<b>Upright Without ToeBoard</b>				
STANDARD UPRIGHT	KGU29	6.7	KGU35	8.5
RAKED UPRIGHT	KGU12	6.7	KGU11	8.5
RADIUSED UPRIGHT	KGUR2	7.5	KGUR	9
BENT UPRIGHT	KGUB2	7.5	KGUB	9
<b>Upright With ToeBoard</b>				
STANDARD TOEBOARD UPRIGHT	KGU29T	6.9	KGU35T	8.8
RAKED TOEBOARD UPRIGHT	KGU12T	6.9	KGU11T	8.8
RADIUSED TOEBOARD UPRIGHT	KGUR2T	7.8	KGURT	9.2
BENT TOEBOARD UPRIGHT	KGUB2T	7.8	KGUBT	9.2

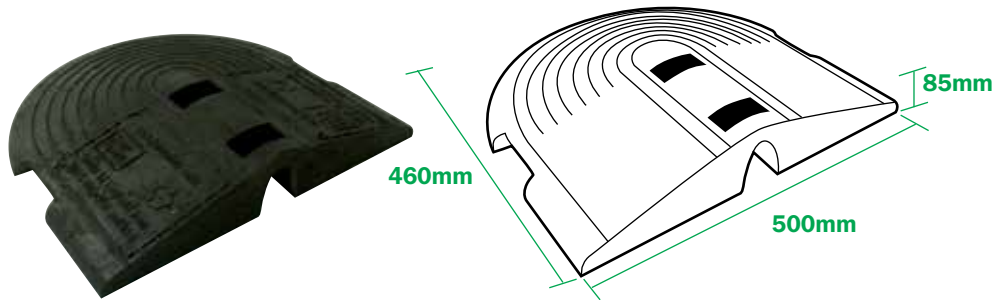

**\*RECYCLED PVC COUNTER WEIGHT - 440-7**

This component provides the stability to the system.  
Material : Recycled PVC Net weight : 13.3kg.

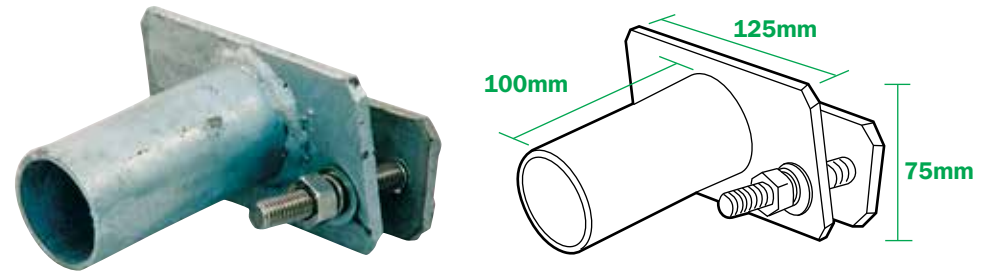

**WALL/LADDER CLAMP - SL109C**

This component provides the means to terminate the system against a façade or clamp the system to a cat ladder/structure where the stringer is a maximum of 70mm wide.  
Material : Galvanised steel to BS EN ISO 1461. Net weight : 1.1kg.



**COLLAR - 74-7**

This component is inserted in the first slot of the recycled PVC Counter Weight. The cantilever tube is pushed through this fitting and the grub screw is then tightened. This component provides the connection between the Cantilever Tube and the Counter Weight.  
Material : Malleable cast iron to BS 1562 and galvanised to BS EN ISO 1461. Net weight : 0.24kg.

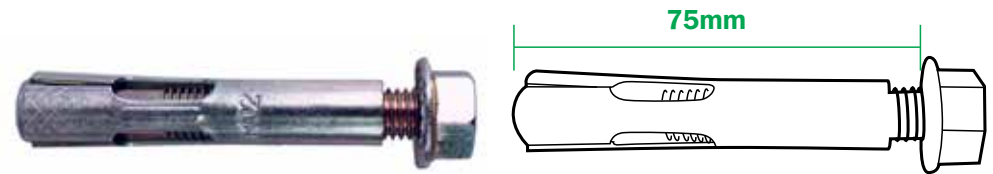

**WALL FIXING - SL110**

The wall fixing is used in pairs in conjunction with a Wall Clamp  
Material : Stainless steel. Net weight : 0.064kg.

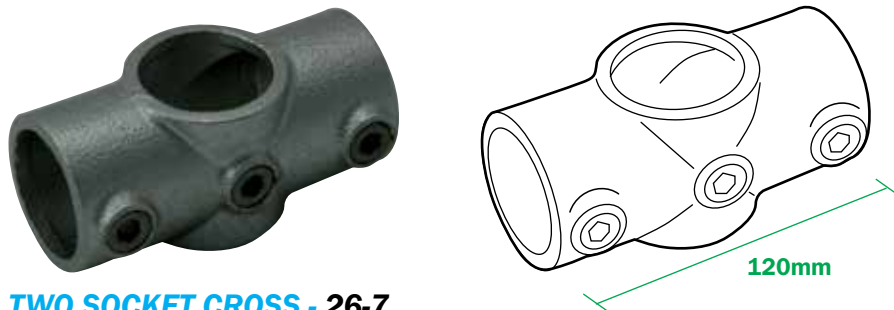

**TWO SOCKET CROSS - 26-7**

This component is used where two recycled PVC Counter Weights need to be joined together to form a counter weight end detail. Material : Malleable cast iron to BS 1562 and galvanised to BS EN ISO 1461. Net weight : 0.63kg.



**PLASTIC CAP - SL105**

This component is fitted to the top of the Support Leg to prevent water ingress.  
Material : PVC. Net weight : 0.009kg.

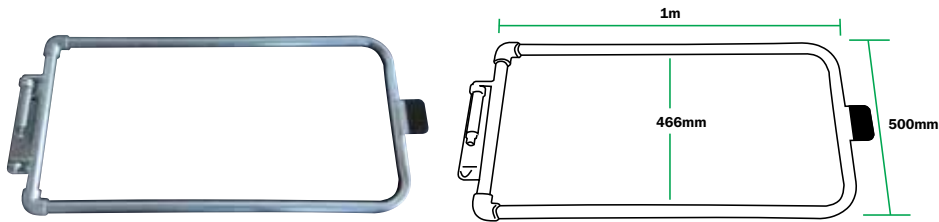

### European Gate - Galvanised - SGEU500GV

Spring Loaded, self-closing safety gate. Manufactured from steel to EN 10255. 33.7mm diameter tube x 3.2mm wall thickness to meet requirements of EN 13374, EN 14122 & BS 13700. Complete with fixing pack.

Material : Galvanised to BS EN ISO 1461 & BS EN 10240. Net weight : 11kg (24lb 4oz).

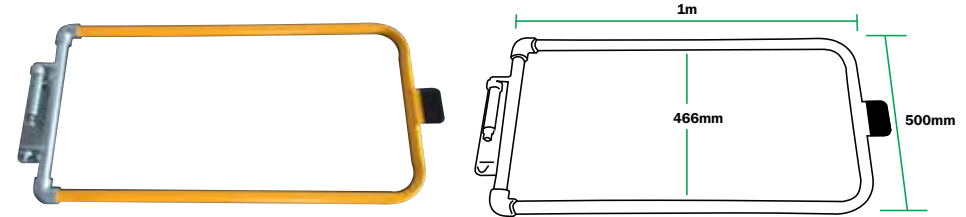

### European Gate - Powder Coated - SGEU500PC

Spring Loaded, self-closing safety gate. Manufactured from steel to EN 10255 33.7mm diameter tube x 3.2mm wall thickness to meet requirements of requirements of EN 13374, EN 14122 & BS 13700.

Complete with fixing pack. Powder Coated Finish to EN 13438.  
Material : Steel to EN 10255. Net weight : 11kg (24lb 4oz).



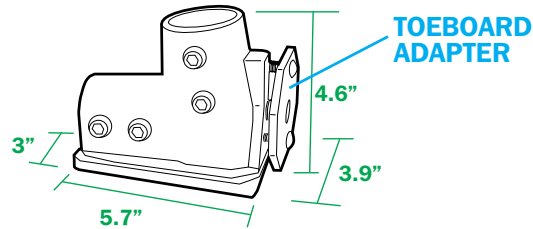

**\*BASE FOOT - 11308-7510 (T1308-7510-TOE-BOARD-OPTION)**

This unique component provides support to the system and allows the system to be set at 90° or raked back at 11°. The Base Foot connects the Cantilever Tubes and Counter Weights. The base is bonded with fluted rubber matting for membrane protection.

Material : Malleable cast iron to ASTM A47-77-32510 and galvanised to ASTM 153 Net weight : 4lb 3oz.

**REPLACEMENT RUBBER PAD - K1351-4080**

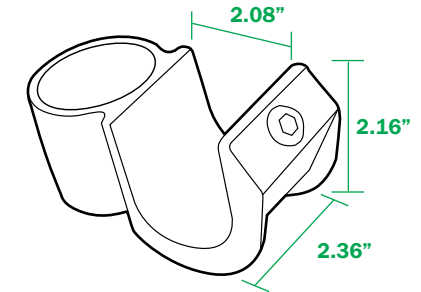

**\*SADDLE CLAMP - 135-8**

This open cup fitting provides the method of linking the horizontal Main Rail Tubes to the Support Legs. Material : Malleable cast iron to ASTM A47-77-32510 and galvanised to ASTM 153. Net weight : 1lb 11oz.

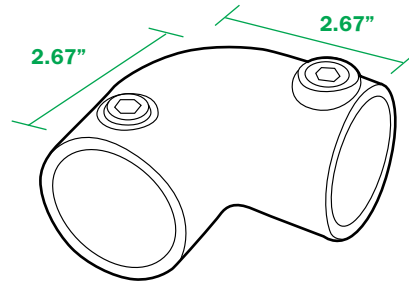

**90° ELBOW - 15-8**

This provides the means of dealing with corners and changes in level.

Material : Malleable cast iron to ASTM A47-77-32510 and galvanised to ASTM 153.

Net weight : 1lb 11oz.

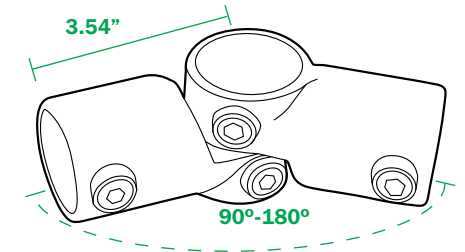

**ADJUSTABLE SIDE OUTLET TEE ELBOW - 19-8**

Used in pairs these components deal with angles 90°-180° and changes in level.

Material : Malleable cast iron to ASTM A47-77-32510 and galvanised to ASTM 153.

Net weight : 2lb 3oz.

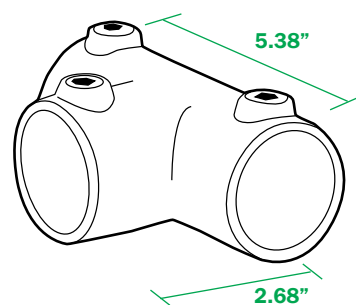

**THREE SOCKET TEE CONNECTOR - 25-8**

This component can be used in many different instances, for example, changes in level.

Material : Malleable cast iron to ASTM A47-77-32510 and galvanised to ASTM 153.

Net weight : 2lb 6oz.

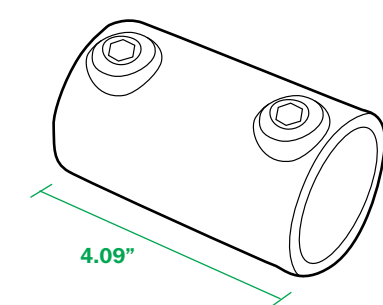

**STRAIGHT COUPLING - 14-8**

This component provides the method to link the horizontal Main Rail Tubes.

Material : Malleable cast iron to ASTM A47-77-32510 and galvanised to ASTM 153.

Net weight : 1lb 5oz.

**\* Sold as replacement parts only**

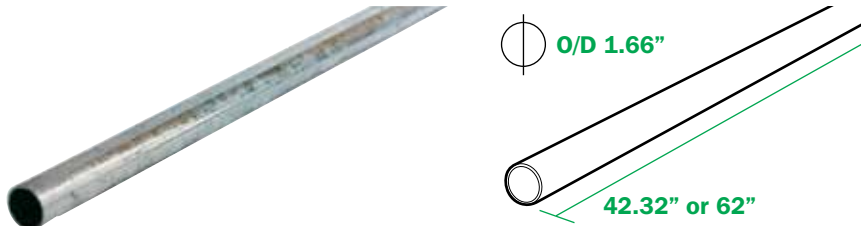

### CANTILEVER TUBE - (42.32" - CBT1) (62" - CBT2)

This component provides the link between the Counter Weight and Base Foot.  
 Material : Gatorshield ASTM A-500 Carbon Steel. Zinc Spelter - ASTM B-6 High Grade Special High Grade Zinc. Cantilever tubes are produced in steel - 1.66" external diameter. (Wall thickness 0.109") First/last Cantilever tube length 62" Net weight : 9lb 14oz Intermediate cantilever tube length 42.32" Net weight : 7lb 3oz.

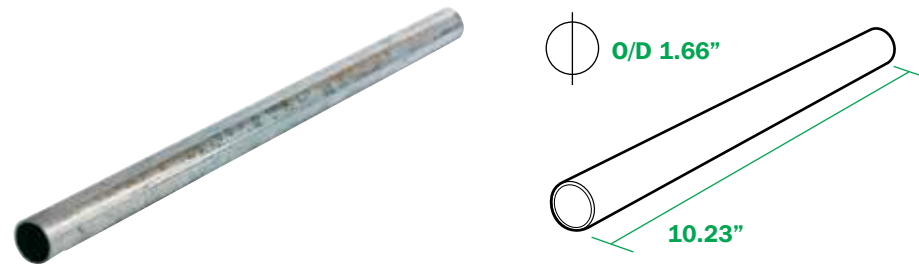

### SMALL CANTILEVER TUBE/COUNTER WEIGHT LINK - CBT3

Used in pairs at the end details these components provide the link between the Counter Weights and the Cantilever Tube via the Two Socket Cross fitting. Material : Gatorshield ASTM A-500 Carbon Steel. Zinc Spelter - ASTM B-6 High Grade Special High Grade Zinc. Tubes are produced in steel - 1.66" external diameter. (Wall thickness 0.109") Net weight : 1lb 5oz.



### MAIN RAIL TUBE (Cut to size - G150GS12GA)

Supplied in three sizes for convenience, these components provide the horizontal rails of the system. Guardrail top and intermediate rails are produced in steel - 1.9" external diameter (Wall thickness 0.109"). Material : Gatorshield ASTM A-500 Carbon Steel. Zinc Spelter - ASTM B-6 High Grade Special High Grade Zinc. Net weight : 50lb 7oz, 25lb 4oz. & 16lb 12oz.

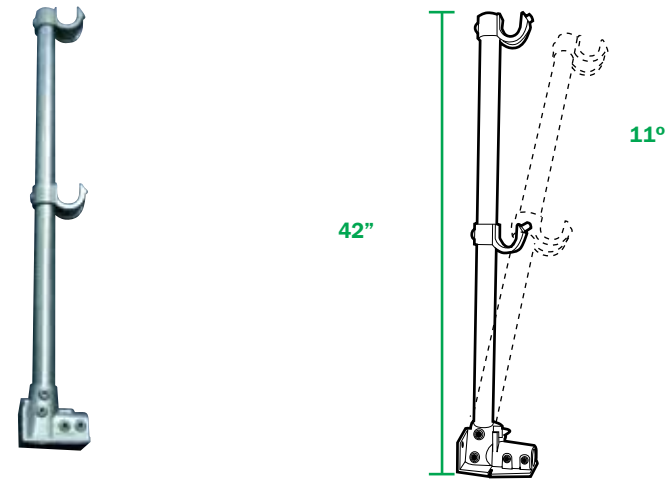

### STANDARD FOLDING SUPPORT LEG - KGU135

This component allows for standard 90° installation or raked back at 11° and provides some height adjustment to the system. The vertical support legs are produced in steel - 1.9" external diameter (Wall thickness 0.109"). Material : Gatorshield ASTM A-500 Carbon Steel. Zinc Spelter - ASTM B-6 High Grade Special High Grade Zinc. Net weight : 15lb 7oz.

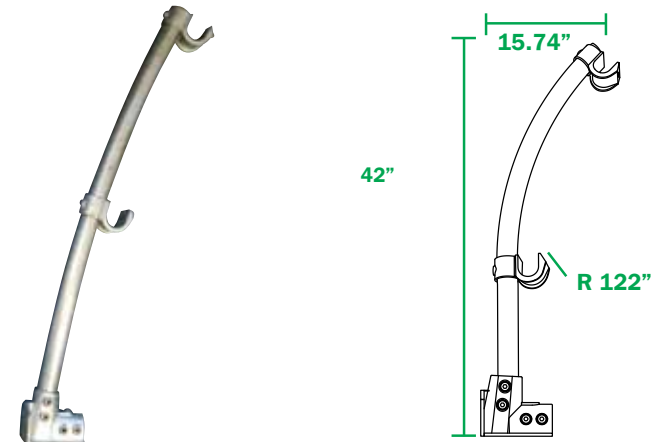

### RADIUSED SUPPORT LEG - KGUR135

This is designed to allow the system to be radiused and gentle curved back towards the roof slope. This component provides some height adjustment to the system. The vertical Support Legs are produced in steel - 1.9" external diameter (Wall thickness 0.109"). Material : Gatorshield ASTM A-500 Carbon Steel. Zinc Spelter - ASTM B-6 High Grade Special High Grade Zinc. Net weight : 17lb 3oz.

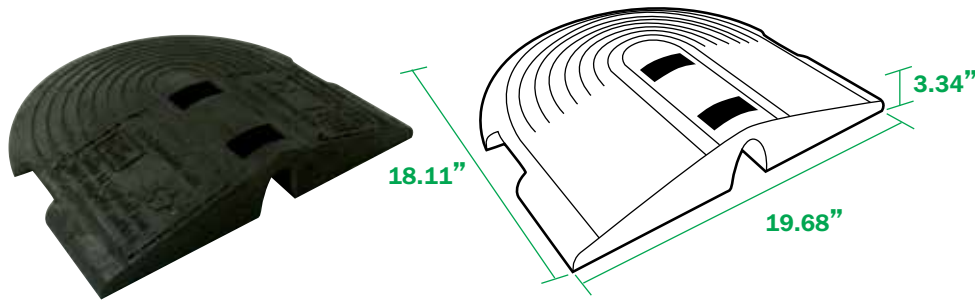

**\*RECYCLED PVC COUNTER WEIGHT - 440-7**

This component provides the stability to the system.  
Material : Recycled PVC Net weight : 29lb 5oz.

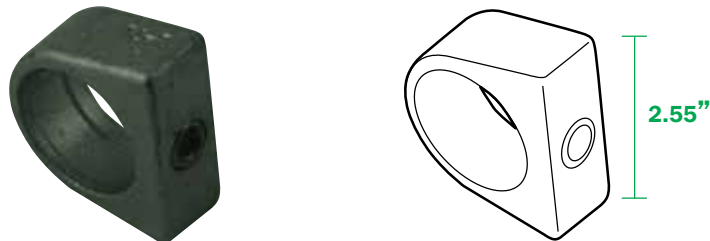

**COLLAR - 74-7**

This component is inserted in the first slot of the recycled PVC Counter Weight. The cantilever tube is pushed through this fitting and the grub screw is then tightened. This component provides the connection between the Cantilever Tube and the Counter Weight.  
Material : Malleable cast iron to ASTM A47-77-32510 and galvanised to ASTM 153.  
Net weight : 8oz.

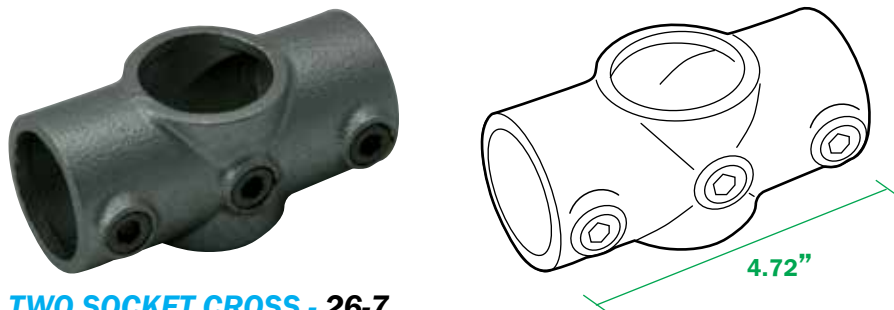

**TWO SOCKET CROSS - 26-7**

This component is used where two recycled PVC Counter Weights need to be joined together to form a counter weight end detail. Material : Malleable cast iron to ASTM A47-77-32510 and galvanised to ASTM 153.. Net weight : 1lb 6oz.

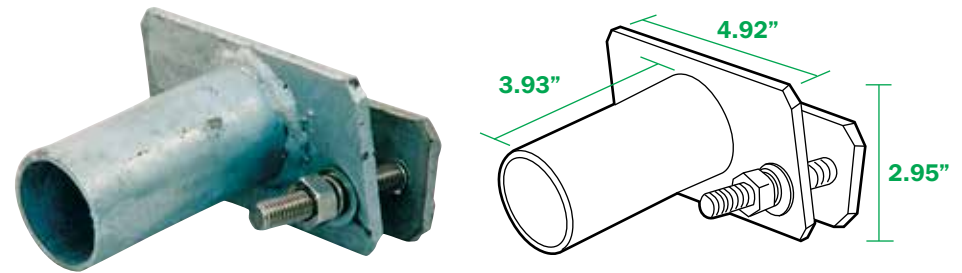

**WALL/LADDER CLAMP - SL109C**

This component provides the means to terminate the system against a façade or clamp the system to a cat ladder/structure where the stringer is a maximum of 2.75" wide.  
Material : Galvanised steel to ASTM A53. Net weight : 2lb 7oz.

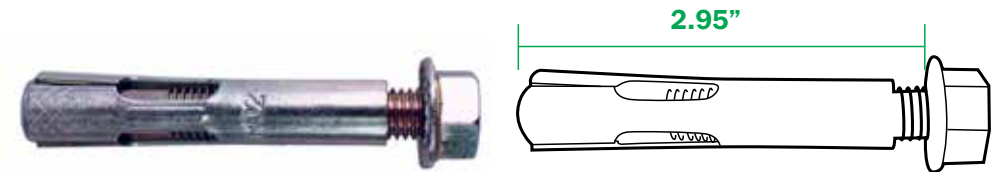

**WALL FIXING - SL110**

The wall fixing is used in pairs in conjunction with a Wall Clamp  
Material : Stainless steel. Net weight : 2oz.

**CANTILEVERED ROOF EDGE PROTECTION**  
SEPARATING PEOPLE FROM HAZARDS

- THIS GUARDRAIL IS TESTED TO EN 13374/EN 14122-3
- THIS GUARDRAIL IS TESTED TO BS 13700: PERMANENT COUNTERWEIGHTED GUARDRAIL SYSTEMS- SPECIFICATION
- DO NOT REMOVE, TAMPER, ADJUST, REMOVE OR ALTER IN ANY WAY THE GUARDRAIL INSTALLATION WITHOUT FIRST CONSULTING KEE SAFETY.
- NO UNLAVED LIFE LINE OR FALL ARREST PRODUCTS TO BE ATTACHED TO THE GUARDRAIL AT ANY TIME
- DO NOT ATTACH PLASTIC SHEETING OR ANYTHING THAT WOULD INCREASE THE WIND LOADING ON THE GUARDRAIL.
- IF YOU FIND THE GUARDRAIL HAS BEEN ALTERED OR DAMAGED WITH CONTACT KEE SAFETY IMMEDIATELY

**HEAD OFFICE**  
Kee Safety Limited  
Cradley Business Park  
Overend Road  
Cradley Heath  
West Midlands B64 7DW

(t) +44 (0) 1384 632 188  
(f) +44 (0) 1384 632 192  
(e) info@keesafety.co.uk  
(w) www.keesafety.co.uk

• RE-TEST ONLY TO BE CARRIED OUT BY AUTHORISED SERVICE AGENT.

**SYSTEM PLAQUE - SL 111**

Provides details of the system and approvals. Material : Plastic. Net weight : 1/3 oz.

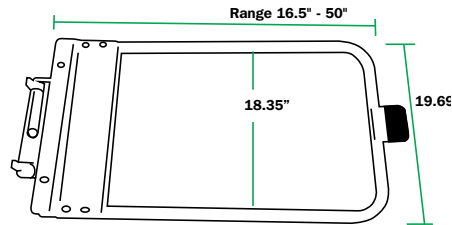

### NORTH AMERICAN GATE - GALVANISED

Spring Loaded, self-closing safety gate for North America. Each model can be adjusted on site without need for cutting or welding. Complete with fixing pack.

Material : Galvanised steel to ASTM A53.

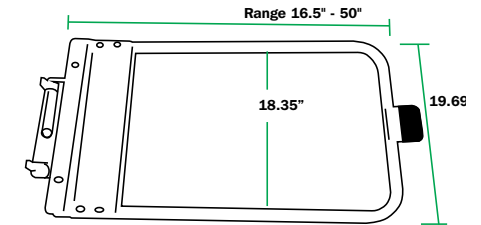

### NORTH AMERICAN GATE - POWDER COATED

Spring Loaded, self-closing safety gate for North America. Each model can be adjusted on site without need for cutting or welding. Complete with fixing pack.

Powder Coated USA - AAMA 2603-2605.

Material : Galvanised steel to ASTM A53.

#### IMPERIAL

##### Single Safety Gate - Imperial

Part No.	Description	Min (in)	Mid (in)	Max (in)	Weight (lbs)
SGNA018GV	18" Gate - Galvanised	16.5	18	20	37lbs 10oz
SGNA018PC	18" Gate - Powder Coated				
SGNA021GV	21" Gate - Galvanised	19.5	21	23	38lbs 11oz
SGNA021PC	21" Gate - Powder Coated				
SGNA024GV	24" Gate - Galvanised	22.5	24	26	38lbs 13oz
SGNA024PC	24" Gate - Powder Coated				
SGNA027GV	27" Gate - Galvanised	25.5	27	29	39lbs 15oz
SGNA027PC	27" Gate - Powder Coated				
SGNA030GV	30" Gate - Galvanised	28.5	30	32	41lbs oz
SGNA030PC	30" Gate - Powder Coated				
SGNA033GV	33" Gate - Galvanised	31.5	33	35	41lbs 3oz
SGNA033PC	33" Gate - Powder Coated				
SGNA036GV	36" Gate - Galvanised	34.5	36	38	42lbs 5oz
SGNA036PC	36" Gate - Powder Coated				
SGNA040GV	40" Gate - Galvanised	38.5	40	42	43lbs 3oz
SGNA040PC	40" Gate - Powder Coated				
SGNA048GV	48" Gate - Galvanised	46.5	48	50	44lbs 15oz
SGNA048PC	48" Gate - Powder Coated				

#### METRIC

##### Single Safety Gate - Metric

Part No.	Description	Min (mm)	Mid (mm)	Max (mm)	Weight (kg)
SGNA018GV	18" Gate - Galvanised	418	457	508	16.8
SGNA018PC	18" Gate - Powder Coated				
SGNA021GV	21" Gate - Galvanised	494	533	584	17.2
SGNA021PC	21" Gate - Powder Coated				
SGNA024GV	24" Gate - Galvanised	570	610	660	17.5
SGNA024PC	24" Gate - Powder Coated				
SGNA027GV	27" Gate - Galvanised	647	686	737	17.9
SGNA027PC	27" Gate - Powder Coated				
SGNA030GV	30" Gate - Galvanised	723	762	813	18.3
SGNA030PC	30" Gate - Powder Coated				
SGNA033GV	33" Gate - Galvanised	799	838	889	18.6
SGNA033PC	33" Gate - Powder Coated				
SGNA036GV	36" Gate - Galvanised	875	914	965	19.0
SGNA036PC	36" Gate - Powder Coated				
SGNA040GV	40" Gate - Galvanised	977	1016	1067	19.4
SGNA040PC	40" Gate - Powder Coated				
SGNA048GV	48" Gate - Galvanised	1180	1219	1270	20.3
SGNA048PC	48" Gate - Powder Coated				





## STANDARD & RAKED SUPPORT LEG (KGU32) OR RADIUSED SUPPORT LEG (KGUR32)

These are supplied already assembled at the correct height (1100mm) (42") with the Base Foot & saddle Clamps set at the correct position.



## LAYING OUT SUPPORT LEG AND MAIN RAIL TUBES

Lay out the equipment in approximately the positions shown below. Always ensure that you and the equipment are at a safe distance from the roof edge. It is recommended that this distance is no less than 2m (6'6").

Lay out two 6.4m (21') Main Rail Tubes (8610) or (3.2m(10'6") or 2.13m (7')) side by side and in a continual line, for the whole length of the required guardrail (ensure these do not roll towards the roof edge). Then start laying out the Support leg Units. If your start position is from a corner, start laying out the support legs at a maximum of the following centres (EN 13374 & BS 13700 - 3m centres) (EN 14122-3 - 2.4m centres) (OSHA Regs - 8' centres). Please refer to technical specification. Carry on laying out the Support Legs for the required length of guardrail.

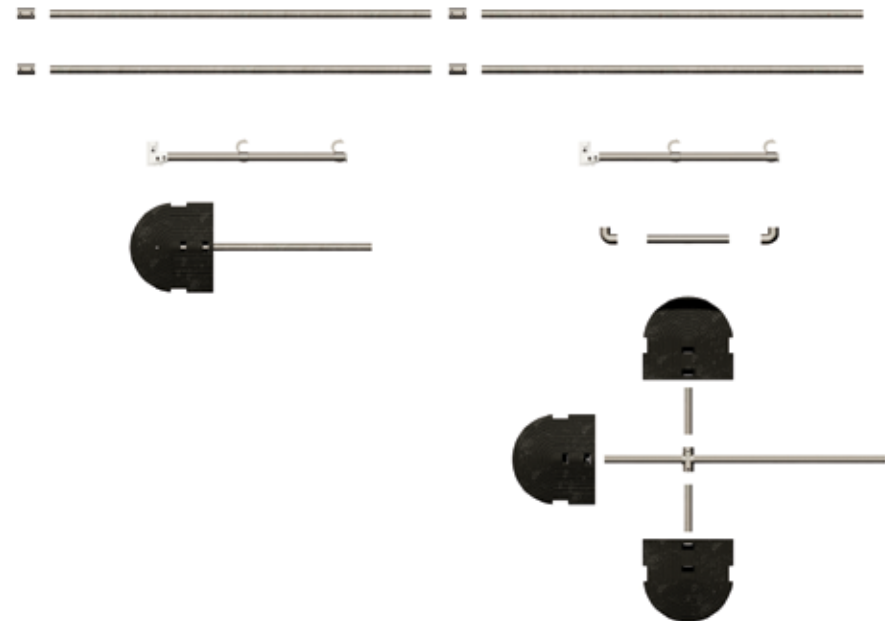

## Fixed, Free Standing and Intermediate Details

(See tables and specifications)



### A

#### SELF CLOSING GATE ACCESS POINT

Extra components

- 1No. Self Closing Gate (GT25P)
- 4No. 90° Elbows (15-8)
- 2No. End pieces
- 6No. PVC Counter Weights (440-7) (EN 13374) (BS13700)
- 2No. Cantilever Tube (CBT2)
- 4No. Small Cantilever Tube Link (CBT3)
- 2No. Two Socket Cross (26-7)
- 6No. Collars (74-7)

- 6No. PVC Counter Weights (440-7) (EN 14122-3)
- 2No. Cantilever Tube (CBT2)
- 8No. Small Cantilever Tube Link (CBT3)
- 4No. Two Socket Cross (26-7)
- 8No. Collars (74-7)

- 14No. PVC Counter Weights (440-7) (OSHA Regs)
- 2No. Cantilever Tube (CBT2)
- 14No. Small Cantilever Tube Link (CBT3)
- 6No. Two Socket Cross (26-7)
- 14No. Collars (74-7)

- 16No. PVC Counter Weights (440-7) (CAL OSHA Regs)
- 2No. Cantilever Tube (CBT2)
- 16No. Small cantilever Tube Link (CBT3)
- 8No. Two Socket Cross (26-7)
- 16No. Collars (74-7)



### B

#### FREE STANDING END

Extra components

- 2No. 90° Elbows (15-8)
- 1No. End piece
- 3No. PVC Counter Weights (440-7) (EN 13374) (BS13700)
- 1No. Cantilever Tube (CBT2)
- 2No. Small cantilever Tube Link (CBT3)
- 1No. Two Socket Cross (26-7)
- 3No. Collars (74-7)

- 4No. PVC Counter Weights (440-7) (EN 14122)
- 1No. Cantilever Tube (CBT2)
- 4No. Small cantilever Tube Link (CBT3)
- 2No. Two Socket Cross (26-7)
- 4No. Collars (74-7)

- 7No. PVC Counter Weights (440-7) (OSHA Regs)
- 1No. Cantilever Tube (CBT2)
- 6No. Small cantilever Tube Link (CBT3)
- 3No. Two Socket Cross (26-7)
- 7No. Collars (74-7)

- 8No. PVC Counter Weights (440-7) (CAL OSHA Regs)
- 1No. Cantilever Tube (CBT2)
- 8No. Small cantilever Tube Link (CBT3)
- 4No. Two Socket Cross (26-7)
- 8No. Collars (74-7)



### C

#### WALL CLAMP

Extra components

- 1No. End piece
- 1No. Three Socket Tee Connector (25-8)
- 1No. Wall/Ladder Clamp (SL109C)
- 2No. 90° Elbows (15-8)
- 2No. Wall Fixings (SL110)

## FIXED, FREE STANDING AND INTERMEDIATE DETAILS LAYING OUT LAYING OUT COUNTER WEIGHTS AND CANTILEVER TUBES

Where the 2No. Main Rail Tubes butt together lay out 2No. Straight Couplings (14-8) in order for the Main Rail Tubes to be joined. At corners 2No. 90° Elbows will be used (15-8).

(Use Adjustable Side Outlet Tee Elbows in pairs where corners are 90° - 180 ° (19-8)).

See also Fixed, Free Standing and Intermediate Details above for additional required components.

(See Figure1.)

### EN13374

At any free standing end detail Support Leg, place 1No. Cantilever Tube (CBT2), 1No. Two Socket Cross Clamp (26-7), 2No. Small Cantilever Tubes (CBT3), 3No. PVC Counter Weights (440-7) and 3No. Collars (74-7)

At the intermediate Support Legs (max 3m centres) place 1No. Cantilever Tube (CBT1), 1No. PVC Counter Weight (440-7), and 1No. Collar (74-7). At corner Support Legs there is no need for a PVC Counter Weight to be connected (See Figure1 and specification.).

### EN 14122-3

At any free standing end detail Support Leg, place 1No. Cantilever Tube (CBT2), 2No. Two Socket Cross Clamp (26-7), 4No. Small Cantilever Tubes (CBT3), 4No. PVC Counter Weights (440-7) and 4No. Collars (74-7)

At the intermediate Support Legs(First bay max 2m centres) (Subsequent bays max 2.4m centres) place 1No. Cantilever Tube (CBT1), 1No. PVC Counter Weight (440-7), and 1No. Collar (74-7). (See Figure1 and specification).

## LAYING OUT FITTINGS

Where the 2No. Main Rail Tubes butt together lay out 2No. Straight Couplings (14-8) in order for the Main Rail Tubes to be joined. At corners 2No. 90° Elbows will be used (15-8).

(Use Adjustable Side Outlet Tee Elbows in pairs where corners are 90° - 180 ° (19-8)).

See also Fixed, Free Standing and Intermediate Details above for additional required components.

(See Figure1.)

### EN 13374 & BS 13700

Roof Type	MAX Pitch	Tube Size	Tube Thickness	End Counter Balance No.'s	MAX Bay Centres	Intermediate Counter Balance No.'s
<b>Mineral Grade Felt</b>						
Restrained	10°	8	2.9mm	CB2	3m	1
UnRestrained	10°	8	2.9mm	CB3	3m	1
<b>PVC Membrane</b>						
Restrained	10°	8	2.9mm	CB2	3m	1
UnRestrained	10°	8	2.9mm	CB7	3m	1
UnRestrained	5°	8	2.9mm	CB5	3m	1

### EN 14122-3 & NF E85-003

Roof Type	MAX Pitch	Tube Size	Tube Thickness	End Counter	MAX End Bay Length	Intermediate Counter Balance No.'s	MAX Subsequent Bay Lengths
<b>Mineral Grade Felt</b>							
UnRestrained	3°	8	3.2mm	CB4	2m	1	2.4m

## FIXED, FREE STANDING AND INTERMEDIATE DETAILS LAYING OUT LAYING OUT COUNTER WEIGHTS AND CANTILEVER TUBES

At any free standing end detail Support Leg, place 1No. Cantilever Tube (CBT2), 3No. Two Socket Cross Clamp (26-7), 6No. Small Cantilever Tubes (CBT3), 7No. PVC Counter Weights (440-7) and 7No. Collars (74-7)

### Subsequent Bays

At the remaining intermediate Support Legs (max 8' centres) place 1No. Cantilever Tube (CBT1), 1No. PVC Counter Weight (440-7), and 1No. Collar (74-7).  
(See Figure and specification).

### CAL OSHA Regs

At any free standing end detail Support Leg, place 1No. Cantilever Tube (CBT2), 4No. Two Socket Cross Clamp (26-7), 8No. Small Cantilever Tubes (CBT3), 8No. PVC Counter Weights (440-7) and 8No. Collars (74-7)

First Bay (3' 3" max) Place 1No. Cantilever Tube (CBT2), 3No. Two Socket Cross Clamp (26-7), 6No. Small Cantilever Tubes (CBT3), 6No. PVC Counter Weights (440-7) and 6No. Collars (74-7)

### Subsequent Bays

At the remaining intermediate Support Legs (max 6' 6" centres) place 1No. Cantilever Tube (CBT1), 1No. PVC Counter Weight (440-7), and 1No. Collar (74-7). (See Figure and specification).

## LAYING OUT FITTINGS

Where the 2No. Main Rail Tubes butt together lay out 2No. Straight Couplings (14-8) in order for the Main Rail Tubes to be joined. At corners 2No. 90° Elbows will be used (15-8).

(Use Adjustable Side Outlet Tee Elbows in pairs where corners are 90° - 180 ° (19-8)).

See also Fixed, Free Standing and Intermediate Details above for additional required components.  
(See Figure1.)

USA & CANADA								
Roof Type	Max Pitch	Tube Size	Tube Thickness (inches)	End Counter Balance No's	End Bay Length (feet)	2nd Vertical Leg Counter Balance No's	Subsequent Counter Balance No's	Susequent Bay Length (feet)
<b>Mineral Grade Felt</b>								
Unrestrained	5°	8	0.109"	CB7	8'	CB1	CB1	8'
Unrestrained	5°	8	0.109"	CB4	3' 3"	CB3	CB1	8'
Unrestrained	10°	8	0.109"	CB8	6' 6"	CB1	CB1	6' 6"
<b>TPO - Single Ply Membrane</b>								
Unrestrained	5°	8	0.109"	CB7	8'	CB1	CB1	8'
Unrestrained	10°	8	0.109"	CB8	6' 6"	CB1	CB1	6' 6"
<b>EPDM - Single Ply Membrane</b>								
Unrestrained	5°	8	0.109"	CB7	8'	CB1	CB1	8'
Unrestrained	10°	8	0.109"	CB8	6' 6"	CB1	CB1	6' 6"

CAL OSHA								
Roof Type	Max Pitch	Tube Size	Tube Thickness (inches)	End Counter Balance No's	End Bay Length (feet)	2nd Vertical Leg Counter Balance No's	Subsequent Counter Balance No's	Susequent Bay Length (feet)
<b>Mineral Grade Felt</b>								
Unrestrained	5°	8	0.109"	CB8	3'3"	CB6	CB1	6'6"

## STAGE 1

Starting at least 2m (6'6") away from the roof edge at the corner, stand up the two Support Legs.



## STAGE 2

Place a Main Rail Tube (8610) into the bottom Saddle Clamp (135-8) of each of the standing legs. Position the tube so there is at least 60mm (2-1/2") protruding from the Saddle Clamp (135-8) and tighten the Grub Screw. These are located on the front of the Saddle Clamp (135-8). Place the second Main Rail Tube (8610) into the top Saddle Clamp (135-8), positioning the tube as before, leaving at least 60mm (2-1/2") of the tube protruding from the Saddle Clamp (135-8) and tighten the Grub Screw of the Saddle Clamp (135-8).



## STAGE 3

Form a corner via connecting 2 No 90° Elbows (15-8) to one end of each of the Main Rail Tubes (8610). Position a further Support Leg (3m max – EN 13374 & BS 13700) (2.4m max – EN 14122-3) (OSHA 8' max) from the corner. Slide a Main Rail Tube (8610) into the bottom Saddle Clamp (135-8) and 90° Elbow (15-8). Slide a Main Rail Tube (8610) into the top Saddle Clamp (135-8) and 90° Elbow (15-8). Tighten the grub screws of all clamps.



## STAGE 4

Working in pairs carefully lift the assembled bay and walk towards the leading edge. Carefully place the bay in the desired position and slide the corresponding Counter Weight tube into the Base Foot. (CBT1 (Intermediate Support Leg or CBT2 (Free Standing End Detail). Always ensure the bay is being held in position whilst carrying out this part of the assembly. At corner Support Legs there is no need for a PVC Counter Weight to be connected.



## STAGE 5

Intermediate support Legs/PVC Counter Weights Slide 1No. Cantilever Tube (CBT1) into the Base Foot. Do not tighten at this stage. Place 1No. Collar (74-7) in the front slot of the PVC Counter Weight. Slide 1No. PVC Counter Weight on to the free end of the Cantilever Tube (CBT1). Line and level guardrail. Tighten all grub screws.



## STAGE 6

Working away from the corner slide a Straight Coupling (14-8) on to the top and intermediate Main Rail Tubes. Ensure the Straight Couplings (14-8) are off set as shown. As far as possible only use one Straight Coupling (14-8) per bay. Stand up the next Support Leg at the desired position (3m max – EN 13374 & BS 13700) (2.4m max – EN 14122-3) (OSHA 8' max) .Continue with this method of fitting the Main Rail Tube (8610) and Support Legs together for this run of guardrail, remembering to connect the intermediate Cantilever Tubes (CBT1) and PVC Counter Weights (440-7) to the Support Legs as you proceed.



## STAGE 7

Free Standing End Details (Refer to tables within specification page)

### EN 13374 & BS 13700

Slide 1No. Two Socket Cross (26-7) on to the free end of the Cantilever Tube (CBT2). Do not tighten at this stage. Slide 2No. Small Cantilever Tubes into the free ends of the Two Socket Cross (26-7) and tighten the grub screws holding these tubes into position. Place 1No. Collar (74-7) in the front slot of each PVC Counter Weight. Slide 1No. PVC Counter Weight on to the free end of the Cantilever Tube (CBT2). Slide 1No. PVC Counter Weight on to each of the free ends of the Small Cantilever Tube (CBT3).

### EN 14122-3

Slide 2No. Two Socket Cross (26-7) on to the free end of the Cantilever Tube (CBT2). Do not tighten at this stage. Slide 4No. Small Cantilever Tubes into the free ends of each of the Two Socket Cross (26-7) and tighten the grub screws holding these tubes into position. Place 1No. Collar (74-7) in the front slot of each PVC Counter Weight. Slide 1No. PVC Counter Weight on to each of the free ends of the Small Cantilever Tube (CBT3).

### OSHA Regs

Slide 3No. Two Socket Cross (26-7) on to the free end of the Cantilever Tube (CBT2). Do not tighten at this stage. Slide 6No. Small Cantilever Tubes into each of the free ends of the Three Socket Cross (26-7) and tighten the grub screws holding these tubes into position. Place 1No. Collar (74-7) in the front slot of each PVC Counter Weight. Slide 1No. PVC Counter Weight on to the free end of the Cantilever Tube (CBT2). Slide 1No. PVC Counter Weight on to each of the free ends of the Small Cantilever Tube (CBT3).

### CAL OSHA Regs

Slide 4No. Two Socket Cross (26-7) on to the free end of the Cantilever Tube (CBT2). Do not tighten at this stage. Slide 8No. Small Cantilever Tubes into each of the free ends of the Three Socket Cross (26-7) and tighten the grub screws holding these tubes into position. Place 1No. Collar (74-7) in the front slot of each PVC Counter Weight. Slide 1No. PVC Counter Weight on to the free end of the Cantilever Tube (CBT2). Slide 1No. PVC Counter Weight on to each of the free ends of the Small Cantilever Tube (CBT3).

Position all PVC Counter Weights as far from the Base Foot (130-875) as practically possible. Line and level guardrail. Tighten all grub screws. (See Fixed, Free Standing and intermediate Details).

## WARNING

Under no circumstances should any person be anchored to the system for fall arrest purposes. Further, components such as timber infill, advertising boards, polyethylene sheets must not be fixed to the system.

# KeeGuard Assembly Guide

## EN 13374 & BS 13700

Roof Type	MAX Pitch	Tube Size	Tube Thickness	End Counter Balance No.'s	MAX Bay Centres	Intermediate Counter Balance No.'s
<b>Mineral Grade Felt</b>						
Restrained	10°	8	2.9mm	CB2	3m	1
UnRestrained	10°	8	2.9mm	CB3	3m	1
<b>PVC Membrane</b>						
Restrained	10°	8	2.9mm	CB2	3m	1
UnRestrained	10°	8	2.9mm	CB7	3m	1
UnRestrained	5°	8	2.9mm	CB5	3m	1

## EN 14122-3 & NF E85-003

Roof Type	MAX Pitch	Tube Size	Tube Thickness	End Counter	MAX End Bay Length	Intermediate Counter Balance No.'s	MAX Subsequent Bay Lengths
<b>Mineral Grade Felt</b>							
UnRestrained	3°	8	3.2mm	CB4	2m	1	2.4m

## USA & CANADA

Roof Type	Max Pitch	Tube Size	Tube Thickness (inches)	End Counter Balance No's	End Bay Length (feet)	2nd Vertical Leg Counter Balance No's	Subsequent Counter Balance No's	Susequent Bay Length (feet)
<b>Mineral Grade Felt</b>								
Unrestrained	5°	8	0.109"	CB7	8'	CB1	CB1	8'
Unrestrained	5°	8	0.109"	CB4	3' 3"	CB3	CB1	8'
Unrestrained	10°	8	0.109"	CB8	6' 6"	CB1	CB1	6' 6"
<b>TPO - Single Ply Membrane</b>								
Unrestrained	5°	8	0.109"	CB7	8'	CB1	CB1	8'
Unrestrained	10°	8	0.109"	CB8	6' 6"	CB1	CB1	6' 6"
<b>EPDM - Single Ply Membrane</b>								
Unrestrained	5°	8	0.109"	CB7	8'	CB1	CB1	8'
Unrestrained	10°	8	0.109"	CB8	6' 6"	CB1	CB1	6' 6"



## CAL OSHA

Roof Type	Max Pitch	Tube Size	Tube Thickness (inches)	End Counter Balance No's	End Bay Length (feet)	2nd Vertical Leg Counter Balance No's	Subsequent Counter Balance No's	Susequent Bay Length (feet)
<b>Mineral Grade Felt</b>								
Unrestrained	5°	8	0.109"	CB8	3'3"	CB6	CB1	6'6"



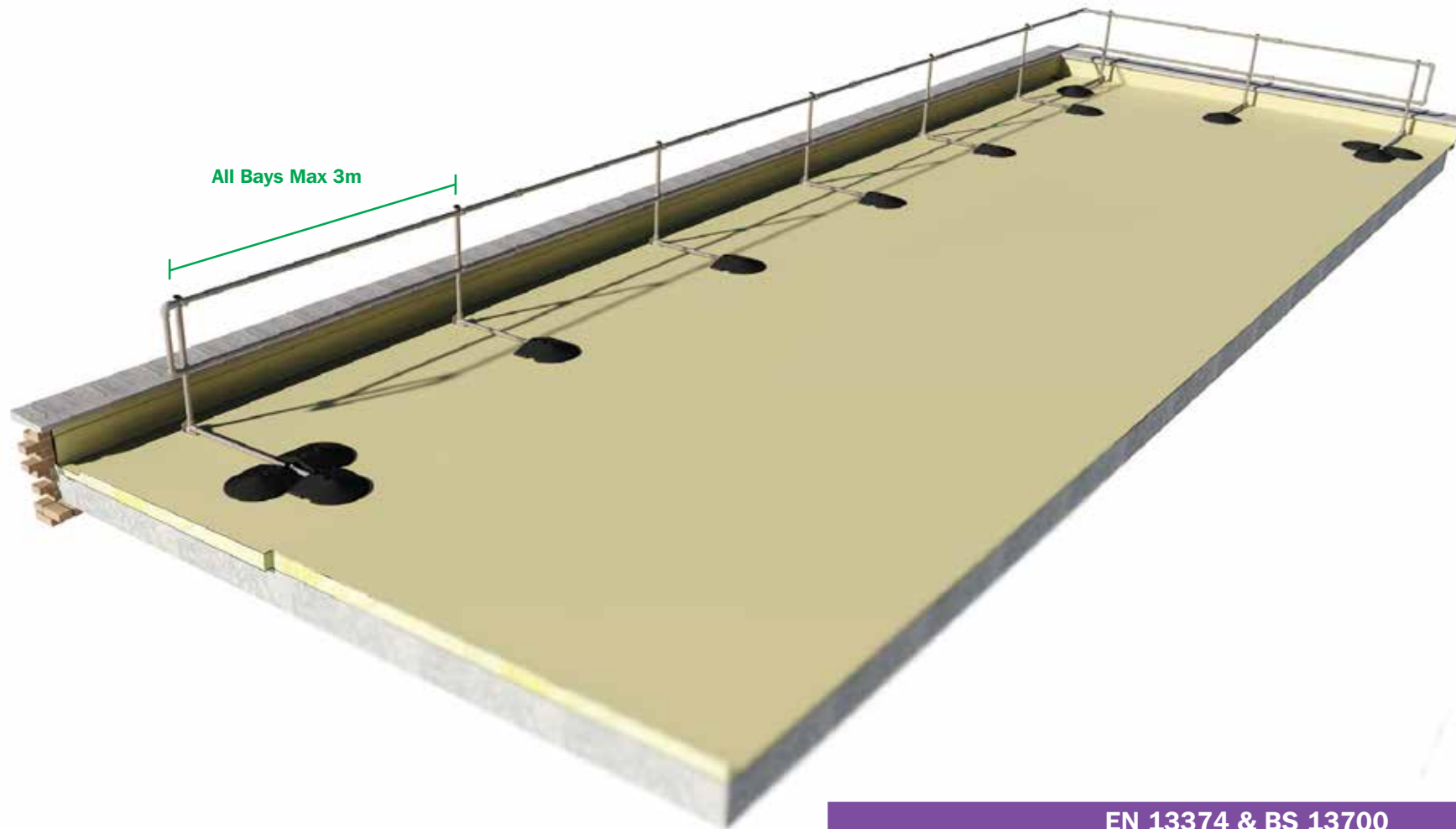

### EN 13374 & BS 13700

Roof Type	MAX Pitch	Tube Size	Tube Thickness	End Counter Balance No.'s	MAX Bay Centres	Intermediate Counter Balance No.'s
<b>Mineral Grade Felt</b>						
Restrained	10°	8	2.9mm	CB2	3m	1
UnRestrained	10°	8	2.9mm	CB3	3m	1
<b>PVC Membrane</b>						
Restrained	10°	8	2.9mm	CB2	3m	1
UnRestrained	10°	8	2.9mm	CB7	3m	1
UnRestrained	5°	8	2.9mm	CB5	3m	1

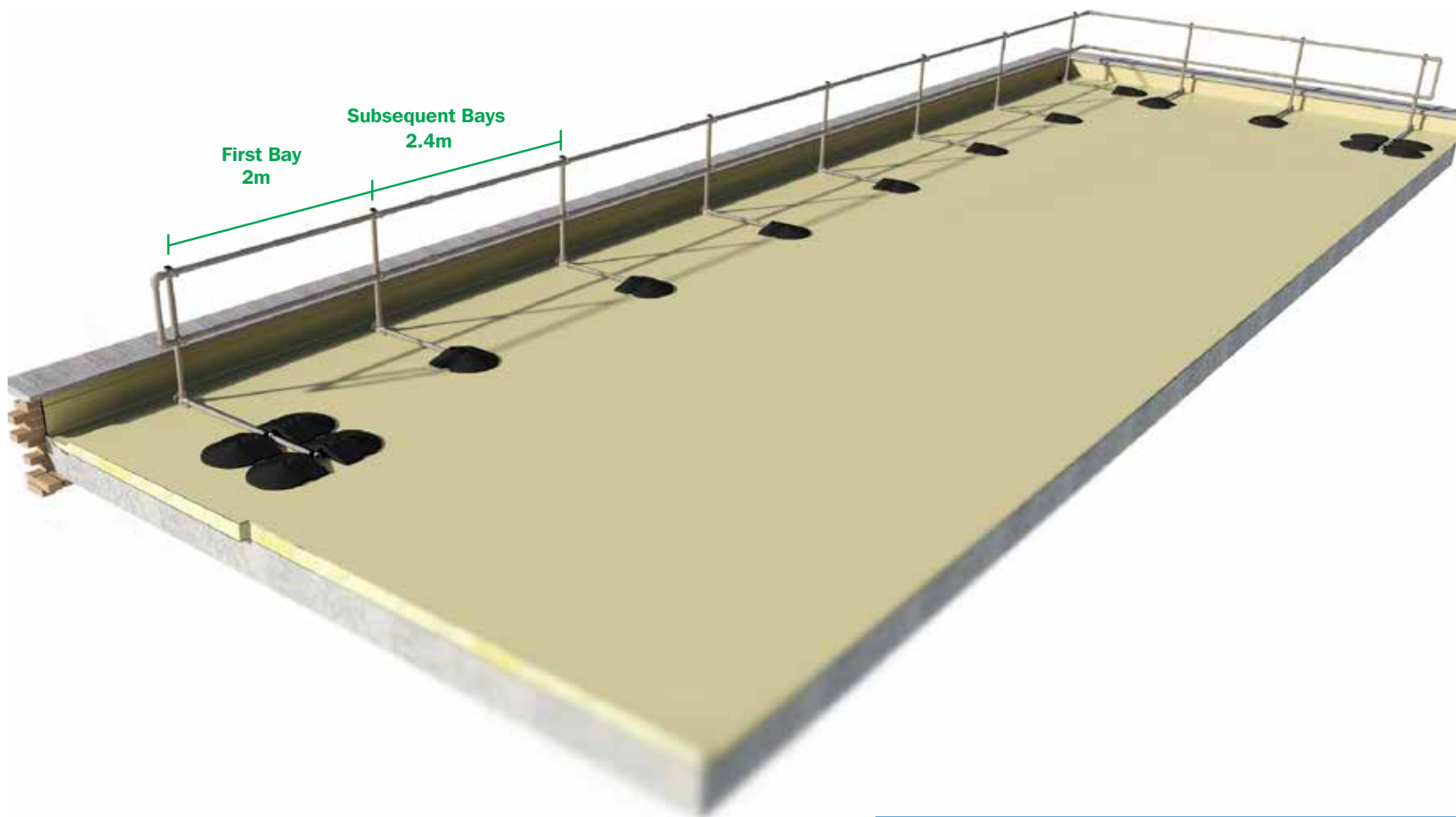

## EN 14122-3 & NF E85-003

Roof Type	MAX Pitch	Tube Size	Tube Thickness	End Counter	MAX End Bay Length	Intermediate Counter Balance No.'s	MAX Subsequent Bay Lengths
<b>Mineral Grade Felt</b>							
UnRestrained	3°	8	3.2mm	CB4	2m	1	2.4m

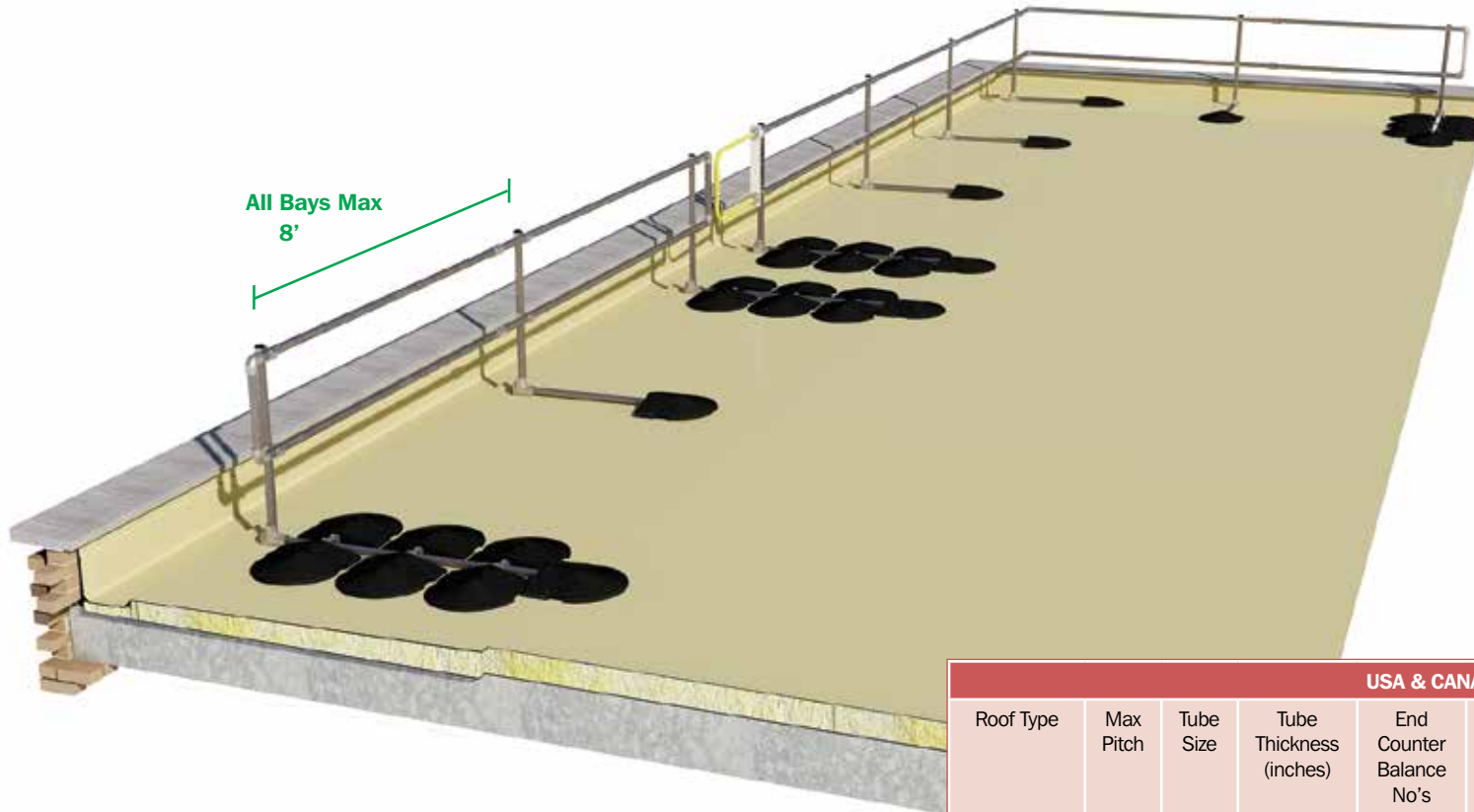

USA & CANADA								
Roof Type	Max Pitch	Tube Size	Tube Thickness (inches)	End Counter Balance No's	End Bay Length (feet)	2nd Vertical Leg Counter Balance No's	Subsequent Counter Balance No's	Susequent Bay Length (feet)
<b>Mineral Grade Felt</b>								
Unrestrained	5°	8	0.109"	CB7	8'	CB1	CB1	8'
Unrestrained	5°	8	0.109"	CB4	3' 3"	CB3	CB1	8'
Unrestrained	10°	8	0.109"	CB8	6' 6"	CB1	CB1	6' 6"
<b>TPO - Single Ply Membrane</b>								
Unrestrained	5°	8	0.109"	CB7	8'	CB1	CB1	8'
Unrestrained	10°	8	0.109"	CB8	6' 6"	CB1	CB1	6' 6"
<b>EPDM - Single Ply Membrane</b>								
Unrestrained	5°	8	0.109"	CB7	8'	CB1	CB1	8'
Unrestrained	10°	8	0.109"	CB8	6' 6"	CB1	CB1	6' 6"

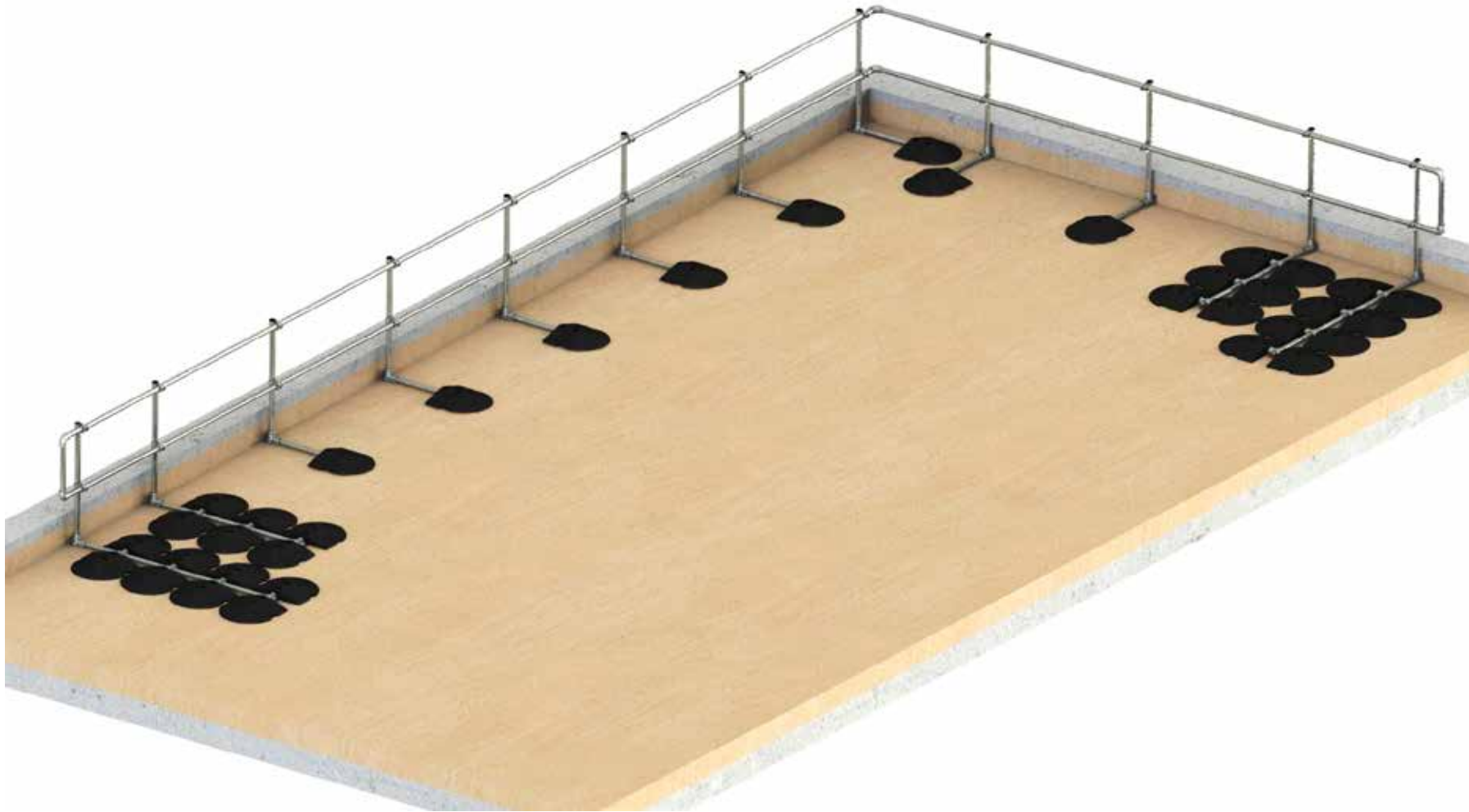

CAL OSHA								
Roof Type	Max Pitch	Tube Size	Tube Thickness (inches)	End Counter Balance No's	End Bay Length (feet)	2nd Vertical Leg Counter Balance No's	Subsequent Counter Balance No's	Susequent Bay Length (feet)
<b>Mineral Grade Felt</b>								
Unrestrained	5°	8	0.109"	CB8	3'3"	CB6	CB1	6'6"



- Periodic inspections by a competent person are recommended by the manufacturer. In UK/Europe these are required under Regulation 5 of the Workplace (Health, Safety & Welfare) Regulations, the Work at Height Regulations and BS EN 365 & BS 13700. The frequency will depend upon the environment, location and usage but should be at least every 12 months.
- Walk and visually inspect the complete installed system in relation to the general client's needs. Establish if any modifications and/or additional products are required to reflect any refurbishment requirements or additional plant & equipment which have been installed and require access.
- Check installation configuration is complete as per the original installation drawing/plan.
- Ensure the system has not been modified or tampered with by unauthorised persons.
- Check all base feet are in contact with the roof membrane.
- Check all counter weights are in place as per the original drawing. This is essential for wind loading calculations.
- Check all grub screws are in place, greased and sufficiently torque.
- Check that the general height and level of the system including the leg centres.  
(This only tends to be an issue if the system has been tampered with between inspections).
- Any galvanised components showing signs of corrosion should be wire brushed thoroughly and galvanised spray/paint applied as appropriate. If rusted significantly, take digital photographs and include these in the inspection report.
- Where toe-boards are fitted check the brackets that support the toe-board are in place, greased and sufficiently torqued.
- Where applicable, check fixings to walls/structures including cat ladder clamps are in place, greased and sufficiently torqued.
- Check system plaque position & mark up to reflect date of the next required inspection. Establish if additional plaques are required due to any refurbishment works.





**Kee Safety Saudi Arabia**  
(Inc. as KIG Safety Equipment Ltd)  
T: +966 552265026  
E: Sales-SaudiArabia@keesafety.com  
keesafety.sa